



# ISLAND CITY DEVELOPMENT AGENDA

**AGENDA**                    **REGULAR MEETING OF ISLAND CITY DEVELOPMENT**  
**DATE & TIME**            **Wednesday, May 20, 2026 - 6:32 PM**

**LOCATION**

Public access to this meeting is available as follows:

To Attend In-Person -

Independence Plaza - 703 Atlantic Ave, Ruth Rambeau Memorial Community Room,  
Alameda, CA 94501

**PUBLIC PARTICIPATION** Join Zoom Meeting

<https://us06web.zoom.us/j/85229497654?pwd=ERF4c2daq8Agm7t8SwqaXfix0iHEve.1>

Meeting ID: 852 2949 7654

Passcode: 141405

---

One tap mobile

+16694449171,,85229497654#,,,,\*141405# US

+12532158782,,85229497654#,,,,\*141405# US (Tacoma)

Persons wishing to address the Board of Directors are asked to submit comments for the public speaking portion of the Agenda as follows:

- Send an email with your comment(s) to [rnavati@alamedahsg.org](mailto:rnavati@alamedahsg.org) or [hainfo@alamedahsg.org](mailto:hainfo@alamedahsg.org) prior to or during the Board of Directors meeting.
- Call and leave a message at (510) 747-4361.
- Complete a speaker card in the meeting room on the day of the meeting.

Written comments may also be submitted via US Mail to:

Island City Development

Attn: Clerk or the Board

701 Atlantic Avenue

Alameda, CA 94501

Written comments received by Island City Development prior to 12 Noon on the day of the meeting will be posted on Island City Development's website and presented at the meeting during the public comment period. Written comments received by Island City Development after 12 Noon, but prior to the meeting start time, will only be presented during the public comment period. Please mark any submission as "Public Comment" and indicate which agenda item they relate to.

- The public comment period is limited to three minutes per speaker.

Persons in need of special assistance to participate in the meetings of the Island City Development Board of Directors, please contact (510) 747-4325 (voice), TTY/TRS: 711,



or [jpolar@alamedahsg.org](mailto:jpolar@alamedahsg.org). Notification 72 hours prior to the meeting will assist the Island City Development Board of Directors to make reasonable arrangements to ensure accessibility or language assistance.

1. CALL TO ORDER & ROLL CALL
2. REMOTE PARTICIPATION PURSUANT TO RALPH M. BROWN ACT - (Government Code Section 54950 et seq.) ("Brown Act") : The Chair will identify whether any Directors are attending the meeting via teleconference pursuant to the Brown Act.
3. Motion to Accept the Order of the Board of Directors Agenda for for the May 20, 2026 Meeting.
4. Closed Session - 6:32 p.m. - Adjournment to Closed Session to Consider:
  - A. Conference with Legal Counsel - Anticipated Litigation: Significant exposure to litigation pursuant to subdivision (d)(4) of Government Code Section 54956.9: Three potential cases
5. CONSENT CALENDAR (Action)
  - A. Approve the Minutes of the Special ICD Meeting Board of Directors Meeting held on April 13, 2026.
  - B. Accept the Monthly Overview Report for the Housing Development Department.
  - C. Accept the Quarterly Stabilization Report for Linnet Corner.
  - D. Accept the Quarterly Stabilization Report for The Estuary I.
  - E. Accept the Quarterly Development Report for The Estuary II.
  - F. Accept the Quarterly Report for The Poplar.
  - G. Approve the Quarterly Write-off, to March 31, 2026, of Uncollectible Accounts Receivable from Former Residents.
  - H. Ratify the AHA Board of Commissioners' Decision to Authorize the Executive Director to Execute a Consultant Services Agreement between the Housing Authority of the City of Alameda and Aleshire & Wynder, LLP for General Counsel services with a maximum contract amount not to exceed \$250,000 for a three-year term, with two 1-year options.
6. NEW BUSINESS
  - A. Authorize the President to Negotiate and Execute a First Amendment to the Consultant Services Agreement between Mabuhay and Lakehurst LP (Linnet Corner) and J.H. Fitzmaurice Increasing the Contract Amount by \$100,000 for a New Maximum Contract Amount Not to Exceed \$179,626, with an Existing Term of September 19, 2026, and Approved Option to Extend the Contract for One Six-Month Term to March 31, 2027.
  - B. Authorize the President to Negotiate and Execute a First Amendment to



the Consultant Services Agreement between Lakehurst and Mosley LP (The Estuary I) and J.H. Fitzmaurice Increasing the Contract Amount by \$100,000 for a New Maximum Contract Amount Not to Exceed \$307,772, with an existing term of September 19, 2026, and approved option to extend the contract for one six-month term to March 31, 2027.

7. NON-AGENDA (Public Comment)
8. WRITTEN COMMUNICATIONS
9. ORAL COMMUNICATIONS – BOARD MEMBERS AND STAFF
10. ADJOURNMENT

NOTES:

- If you need special assistance to participate in the meetings of the Island City Development Board of Directors, please contact Richa Nanavati at (510) 747-4361 (TTY/TRS: 711) or [rnanavati@alamedahsg.org](mailto:rnanavati@alamedahsg.org). Notification 48 hours prior to the meeting will enable the Island City Development Board of Directors to make reasonable arrangements to ensure accessibility or language assistance.
- Documents related to this agenda are available for public inspection and copying at the Office of the Housing Authority, 701 Atlantic Avenue, during normal business hours.
- Know Your RIGHTS Under The Ralph M. Brown Act: Government’s duty is to serve the public, reaching its decisions in full view of the public. The Board of Directors exists to conduct the business of its constituents. Deliberations are conducted before the people and are open for the people’s review. In order to assist Island City Development’s efforts to accommodate persons with severe allergies, environmental illnesses, multiple chemical sensitivity or related disabilities, attendees at public meetings are reminded that other attendees may be sensitive to various chemical based products. Please help Island City Development accommodate these individuals.

**IF YOU WISH TO ADDRESS THE BOARD:**

- Anyone wishing to address the Board on agenda items or business introduced by Board members may speak for a maximum of three (3) minutes per agenda item when the subject is before the Board. Please file a speaker’s slip with the Board President. Upon recognition by the President, approach the rostrum and state your name.
- Lengthy testimony should be submitted in writing and only a summary of pertinent points presented verbally.
- Applause and demonstrations are prohibited during Board meetings.





**DRAFT UNTIL APPROVED**

**AGENDA**                    **MEETING OF THE BOARD OF DIRECTORS**  
**TYPE**                     **Special**  
**DATE**                    **Monday, April 13, 2026**  
**TIME**                    **7:02 p.m.**

*Counsel Henry Loh from Gubb and Barshay, and Brandon Stracener from Goldfarb and Lipman were present.*

**1. CALL TO ORDER AND ROLL CALL**

*The Board of Directors meeting was called to order at: 9:26 p.m.*

*Directors Vanessa Cooper, Carly Grob, and Alicia Southern were present. Quorum was established.*

**2. REMOTE PARTICIPATION PURSUANT TO RALPH M. BROWN ACT - Chair will identify whether any Directors are attending the meeting via teleconference pursuant to the Brown Act.**

*Director Cooper identified that all Board Directors attended in-person and not via teleconference.*

**3. Motion to Accept the Order of the Board of Directors Agenda for the April 13, 2026, Meeting**

Director Grob moved to accept the motion. Director Southern seconded the motion. Passed Unanimously.

Ayes 3  
Nays 0  
Abstain 0

**4. PUBLIC COMMENT (Non-Agenda)**

No public comment was received.



**5. Closed Session – 7:02 p.m. Adjournment to Closed Session to Consider**

- A. Conference with Legal Counsel – Anticipated Litigation: Consider exposure to significant litigation pursuant to subdivision (d)(2) of Government Code Section 54956.9: One potential case.

*Director Cooper adjourned to Closed Session at 9:31 p.m.*

*Counsel Henry Loh, Counsel Brandon Stracener, Director Cooper, Director Grob, Director Southern, Housing Development Director Sylvia Martinez, and Finance Director Louie So were present for closed session.*

**6. Adjournment of Closed Session.**

*Director Cooper adjourned Closed Session and Reconvened the Special Meeting at 10:06 p.m.*

Announcement of Action Taken in Closed Session, if any:

No reportable action was taken during this closed session.

**7. Reconvene Special Meeting**

*Director Cooper reconvened the Special Meeting at 10:06 p.m.*

*Directors Vanessa Cooper, Carly Grob, and Alicia Southern were present.*

**8. CONSENT CALENDAR (Action)**

■ Consent Calendar items are considered routine and will be approved or accepted by one motion unless a request for removal for discussion or explanation is received from the Board of Commissioners or a member of the public.

- 8-A.** Approve the Minutes of the Regular ICD Board of Directors Meeting held on March 18, 2026.
- 8-B.** Accept the Monthly Overview Report for the Housing Development Department
- 8-C.** Approve the Update to the 2021-2026 Reserve Policy (2026).
- 8-D** A Receive a Report on the Reappointment of Board Member Alicia Southern for a Term Ending April 15, 2028.
- 8-E** Authorize the President to Negotiate and Execute a Seventh Amendment to the Consultant Services Contract between Gubb and Barshay and Mabuhay and Lakehurst LP (Linnet Corner) for ongoing environmental legal services with Nixon Peabody LLP increasing the maximum not to exceed Contract Amount by \$6,000.00 to a new maximum not to exceed contract amount of \$204,365.66 for the total term.



- 8-F** Authorize the President to Negotiate and Execute a Seventh Amendment to the Consultant Services Contract between Gubb and Barshay and Mosley and Mabuhay LP (Estuary II) for ongoing environmental legal services with Nixon Peabody LLP increasing the maximum not to exceed Contract Amount by \$6,000.00 to a new maximum not to exceed amount of \$204,365.67 for the total term, including extensions.
- 8-G** Authorize the President to Negotiate and Execute a Seventh Amendment to the Consultant Services Contract between Gubb and Barshay and Lakehurst and Mosley LP (Estuary I) for ongoing environmental legal services with Nixon Peabody LLP increasing the maximum not to exceed Contract Amount by \$6,000.00 to a new maximum not to exceed contract amount of \$194,365.67 for the total term, including extensions.
- 8-H** Authorize and Approve the President to Negotiate and Execute a Second Amendment to the Amended and Superseded Consultant Services Contract between ENGEO Incorporated, the Housing Authority of the City of Alameda, and Lakehurst and Mosley LP (Estuary I) for geotechnical and environmental services extending the contract term an additional six months to December 31, 2026.
- 8-I** Authorize and Approve the President to Negotiate and Execute a Second Amendment to the Amended and Superseded Consultant Services Contract between ENGEO Incorporated, the Housing Authority of the City of Alameda, and Mosley and Mabuhay LP (Estuary II) for geotechnical and environmental services extending the contract term an additional six months to December 31, 2026.
- 8-J** Authorize and Approve the President to Negotiate and Execute a Second Amendment to the Amended and Superseded Consultant Services Contract between ENGEO Incorporated, the Housing Authority of the City of Alameda, and Mabuhay and Lakehurst LP (Linnet Corner) for geotechnical and environmental services extending the contract term an additional six months to December 31, 2026.

Director Grob moved to accept the motion. Director Southern seconded the motion. Passed Unanimously.

Ayes 3  
Nays 0  
Abstain 0

## **9. NEW BUSINESS**

- 9-A** Approve a Resolution for the Amended and Restated Procurement Policy for Island City Development effective immediately.

Staff S. Martinez presented the proposed changes to the Procurement Policy.

Director Grob moved to accept the motion. Director Southern seconded the motion. Passed Unanimously.

Ayes 3  
Nays 0  
Abstain 0



**10. NON-AGENDA (Public Comment)**

No public comment was received at this time.

**11. WRITTEN COMMUNICATIONS**

No further written communication was presented at this time.

**12. ORAL COMMUNICATIONS, Non-Agenda (Board and Staff)**

No additional oral communications were presented at this time.

**10. ADJOURNMENT**

*The meeting was adjourned at 10:10 p.m.*





**ISLAND CITY DEVELOPMENT**

Fax (510) 522-7848 | TTY/TRS 711

To: Board of Directors  
Island City Development

From: Sylvia Martinez, Director of Housing Development

Date: May 20, 2026

Re: Accept the Monthly Overview Report for the Housing Development Department.

**BACKGROUND**

This memo provides an overview of the Housing Development departmental activities for the prior month

**DISCUSSION**

Island City Development

Currently, the Housing Authority of the City of Alameda (AHA) has a pre-development loan to Island City Development (ICD) for Estuary II through its affiliate Alameda Affordable Housing Corporation (AAHC) via the Alameda Affordable Housing Trust Fund (AAHTF). The AHA Board approved options for ground leases for ICD pipeline projects (Estuary II & The Poplar). There is also a conditional Project-Based Voucher commitment for Estuary II, for forty Project-Based Vouchers. However, due to HUD shortfall this cannot be funded at this time.

Affordable Housing Project Pipeline

- Estuary I – Estuary I is being reviewed for 90 days of stabilized occupancy. Conversion is planned for July 2026. Staff is providing compliance documentation and preparing the CTCAC placed in service application. Staff is also actively reviewing the small construction and warranty projects.
- Linnet Corner is being reviewed for 90 days of stabilized occupancy. Staff is providing compliance documentation and preparing a series of documents required by the State of California for its funding, which is anticipated to be delivered in September 2026. The State has released an opportunity to obtain its funding early, which would save on construction interest costs, starting April 15, 2026. Staff is preparing a package and see if this is a viable alternative for this project. Staff is also actively reviewing the small construction and warranty projects.
- Estuary II – Staff has started the new 2026 application cycle. It submitted an application for City of Alameda HOME fund on April 27, 2026. The March AHP application is scheduled for award notifications in June 2026. Staff is also discussing funding alternatives with the State of California, if available, including the extension



- and augmentation of existing awards.
- North Housing Master Plan – Staff expects the release of the EBMUD infrastructure bond in the next month. The City infrastructure bond will be released summer of 2026. Both bonds are pending final review of the completed work and the first year guarantee.
  - The Poplar (2615 Eagle) – Poplar continues to focus on entitlement steps and early design. Rincon Environmental submitted the results from the seasonal testing to the Water Board for review. Staff requested and received an extension to 2027 to re-submit the Corrective Action Plan (CAP) from the Water Board. A new fence has been installed to keep the site secure. Pest control and weekly site walks continue. An interest list is available for prospective tenants.

### Asset Management Reporting

The 2026-27 Welfare tax exemptions were submitted to the County of Alameda Assessor in late February, on time. Staff is responding to requests for additional information. On May 1, 2026, staff submitted the first tranche of required documents for the tax credit properties to the California Tax Credit Allocation Committee. HD staff supported Finance as they completed the 2025 audits for all the tax credit properties.

### New Funding Opportunities

Housing Development, Finance and Portfolio issued an RFP for debt to refinance the mortgage at Eagle and Parrot Village in March. Please see the related Board report on financing options.

### Construction in Progress

The largest active CIP project is the complete roof replacement at Independence Plaza (IP) and the AHA offices. There has been steady progress despite weather interruptions. Other projects at IP and Anne B. Diament (ABD) are in design and permitting. The multi-site gas shut-off project has also begun. Staff is reviewing the draft FY 26-27 CIP activities list and budget in preparation for the annual budget cycle. AHA's construction management team also led a 100% unit and common area warranty walk at North Housing in February and was able to identify a number of issues that are being referred to the contractor for resolution. Portfolio and HD staff have been partnering on warranty issues at Everett Commons, including the installation of expansion tanks at the water heaters and obtaining legal counsel with regard to ongoing warranty issues.

### Staffing

The department has recently hired two new staff and is working with a part-time AHA former employee/retiree to catch up on key tasks. The department anticipates hosting a summer intern.

### Public Outreach

HD staff released a development pipeline newsletter in April, which includes a link for The Poplar Interest List.

### **FISCAL IMPACT**

None



**CEQA**

Not Applicable

**RECOMMENDATION**

Accept the Monthly Overview Report for the Housing Development Department.

**ATTACHMENTS**

1. Housing Development Newsletter Q1 2026

Respectfully submitted,



Sylvia Martinez, Director of Housing Development

# Housing Development

## DEVELOPMENT PIPELINE QUARTERLY UPDATE

Thank you for your continued interest in our work. We're pleased to share the progress being made to build and preserve affordable housing for people in our community.

### **In Development:**

We are excited to announce that Estuary II is shovel-ready, and the team is actively pursuing funding to bring the project into construction. AHA has already completed all required sidewalk and perimeter site improvements, including construction and dedication of Mabuhay Street to the City of Alameda.

Estuary I and Linnet Corner are now fully leased. The team is working to ensure both properties are running smoothly as they transition into long-term operations by late 2026.

On the Poplar, a new affordable housing community of approximately 50-60 family apartments, the project is moving through California Environmental Quality Act (CEQA) review and entitlements process. In 2025, AHA hosted three community meetings and received a variety of feedback. The next community meeting will occur in 2027 as part of that CEQA process. More information on the project is available at <https://www.alamedahsg.org/project/poplar/> and the Island City Development (ICD) website: <https://islandcitydevelopment.org/project/the-poplar/> There is also an interest list for families and individuals who are interested in living at Poplar : [Sign up for Poplar Interest List](#)



1) New fencing has been installed at 1625 Eagle (Poplar).

## **Construction In Progress:**

Property upkeep is a core part of our work, ensuring our communities remain safe, functional, and long-lasting. Recent improvements include:

- Concrete repairs at Sherman House
- Roofing upgrades at Independence Plaza (ongoing)
- Roof and gutter replacement at the AHA office (completed in March)
- Installation of seismic gas shut-off valves at 10 properties for added safety

Looking ahead, additional upgrades are in progress across multiple properties, including balcony repairs, electrical and water system improvements, ADA upgrades, parking lot safety features, and building renovations. Independence Plaza is also updating site signage to enhance safety.



*2) Concrete repair work completed at Sherman House.*



*3) New roofs being installed at Independence Plaza.*



*4) New roofs being installed at the AHA office.*

## **Events**

With 2026 well underway, we're taking a moment to highlight a few key moments from this past year.

In September, AHA celebrated its 85th anniversary, recognizing staff and local leaders for their ongoing commitment to providing safe, affordable housing in Alameda.

In December, AHA hosted the Northern California and Nevada Chapter of the California Association of Housing Authorities. More than 30 housing professionals from across the region came together to share ideas, best practices and tour local properties.

During the holiday season, AHA partnered with the Alameda Firefighters Toy Program to create an online application which allowed over 230 AHA households to apply for toys through the program. The department also welcomed a new Construction Project Manager and Housing Development Specialist, both of whom are now supporting current and upcoming projects.



2. The AHA 85th celebration venue (Left). Association of Housing Authorities Meeting (Center). Alameda Firefighters Toy Program (Right).

## **Interested in Housing?**

Poplar Interest Form: [Sign up for Poplar Interest List](#)

## **Procurement**

AHA continues to seek qualified vendors and consultants for a range of services. Interested firms can register through Bonfire to view opportunities and submit proposals:

- <https://www.alamedahsg.org/contracting-with-aha>
- <https://alamedahsg.bonfirehub.com/portal/?tab=openOpportunities>

## **Stay Connected**

Sign up for our e-newsletter to receive updates: [www.ahagroup.click](http://www.ahagroup.click)

## **Contact:**

Joshua Altieri, Community Relations Manager  
510-747-4321, [jaltieri@alamedahsg.org](mailto:jaltieri@alamedahsg.org)



# ISLAND CITY DEVELOPMENT

Fax (510) 522-7848 | TTY/TRS 711

To: Board of Directors  
Island City Development

From: Jocelyn Layte, Associate Project Manager

Date: May 20, 2026

Re: Accept the Quarterly Stabilization Report for Linnet Corner.

## **BACKGROUND**

The Housing Development Department provides quarterly reports on projects under construction where either the Housing Authority of the City of Alameda (AHA) or Island City Development (ICD) is acting as developer and provides performance guarantees.

Linnet Corner is located at 2000 Lakehurst Circle, Alameda, CA 94501. The project is the new construction of a single, four (4) story residential building, with sixty-four units. There are forty studio units and twenty-three one-bedroom units targeting seniors and veteran seniors aged sixty-two and over and a two-bedroom manager’s unit. Affordability levels range between 30% and 40% of the Area Median Income (AMI). Sixteen units serve formerly homeless senior veterans. Amenities include a community room, onsite property management and service provider offices, parking, laundry room, a resident garden, and a roof terrace. Linnet Corner achieved a certificate of occupancy to close construction on September 4, 2025.

Please see previous Board of Commissioner reports for project details.

## **DISCUSSION**

### Construction

In December 2025, the Board approved a contract with the project general contractor for upgrades of the property. To date, the contract has used 59% of the total contract amount (\$105,626) for work on the properties' rain gutter systems, awnings, acoustic upgraded ceiling tiles in management and services offices, and landscaping. The work under this contract is complete, but the contract is being held open for any additional work. Staff will conduct a final walk of the property to identify if there are any additional needs or upgrades that could benefit the tenants.

### Operation and Lease-Up Activities

Residential move-ins began the first week of September 2025 and full lease-up was obtained as of February 2026. In early April, staff were notified by the investor that stabilization file reviews were 100% complete and accepted. Forty of the sixty-four units receive Project-Based Vouchers (PBV), and the Housing Assistance Program (HAP) contract is paying as



LifeSTEPS manages intensive case management, resident engagement, and other supportive services. LifeSTEPS receives intensive case management funding from the County of Alameda and files detailed reports on those activities. LifeSTEPS held five resident events with tenants from both properties recently covering topics on health, safety, gardening, and mental wellness.

#### Stabilization and Permanent Financing

Next steps for Linnet Corner include stabilizing operations while achieving key milestones for the project. The project has achieved two of these milestones, including 100% of all tax credit units leased by February 28, 2026, and three full months of 95% occupancy. The project continues to meet the remaining milestones encompassing operations at a 1.10 debt service coverage ratio (this is a ratio that compares income to expenses) by May 1, 2026, and all financial close out documentation such as the final cost certification by September 1, 2026. A draft cost certification was completed by the CPA firm, Novogradac.

The project received its 2025-2026 Welfare exemption for property taxes and applied for the 2026-2027 exemption in February. The project successfully received the remaining \$1.9M of equity from the second capital contribution and the \$6M from the third capital contribution, which will pay down construction sources and save on construction loan interest. Staff are preparing for conversion meetings to begin in June 2026 for a target of September 2026 for loan conversion. The Placed in Service (PIS) package has been drafted for submission to the CA Tax Credit Allocation Committee and CA Dept. of Housing and Community Development in accordance with conversion requirements and is going through internal reviews to finalize the package for submission later this year.

#### Warranty

The project entered the warranty period in September 2025 and will be under warranty for 12 months. During this time, all warranty items have been minor and expediently resolved by the general contractor.

In December, staff released the performance bond on file with the city in regard to the offsite work for Mabuhay. A warranty bond is now on file with the city and will be released in Fall 2026. The offsite portions of North Housing Block A also had an East Bay Municipal Utility District (EBMUD) performance bond in regard to the main water extensions. A sign-off walk was conducted on December 31, 2025, and all work generated via a punch list during the walk was completed by the general contractor J.H. Fitzmaurice. EBMUD is currently completing internal processes and will issue contract acceptance to AHA.

#### Awards/Recognitions

Staff prepared nominations for both Linnet Corner and Estuary I for regional and national awards. Award announcements will be made by the various agencies in early summer through the fall.

#### **FISCAL IMPACT**

AHA and ICD have completion and lease-up guarantees on this development. Linnet Corner is a 4% tax-credit project which is reliant on basis-eligible costs for part of its financing. Changes during construction (including the soil off-haul cost, basis-eligible cost savings, and



interest savings due to lower interest rates) will result in some equity reduction, but the overall budget currently balances with project sources.

**CEQA**

Not applicable.

**RECOMMENDATION**

Accept the Monthly Construction Report for Linnet Corner.

**ATTACHMENTS**

None

Respectfully submitted,



Jocelyn Layte, Associate Project Manager



# ISLAND CITY DEVELOPMENT

Fax (510) 522-7848 | TTY/TRS 711

To: Board of Directors  
Island City Development

From: Jocelyn Layte, Associate Project Manager

Date: May 20, 2026

Re: Accept the Quarterly Stabilization Report for The Estuary I.

## **BACKGROUND**

The Housing Development Department provides monthly reports on projects under construction where either the Housing Authority of the City of Alameda (AHA) or Island City Development (ICD) is acting as developer and provides performance guarantees.

Estuary I is located at 500 Mosley Avenue. The project is a forty-five new construction permanent supportive housing apartment development for unhoused or formerly unhoused individuals or households and includes one manager’s unit. Amenities include property management offices, social service coordination offices, a community room, a mail room, central laundry, central courtyard, pet relief area, and secure bike parking. The development received a Certificate of Occupancy (COO) on August 21, 2025. The project has been fully leased since August 31, 2025.

Please see previous monthly Board Reports for project details prior to this month’s update.

## **DISCUSSION**

### Construction

In December 2025, the Board approved a contract with the project general contractor for upgrades noted during operations that were not included in the original contract. To date, the contract has used 98% of the total contract amount (\$216,420) for work on the properties' rain gutter systems, awnings, acoustic panels, acoustic dampening and upgraded acoustic ceiling tiles in management and services offices, and additional bike room fob entry systems. The contract is being held open for any additional work under this contract.

### Operation and Lease Up Activities

As of January 31, 2026, 100% of the forty-four apartments are leased. However, it is common for permanent supportive housing projects to experience ongoing vacancies and need for leasing due to medical, legal, financial, or other tenant issues causing turnover. Staff continues to review a few back-up referrals from the County of Alameda CES as preparation for this kind of turnover should it occur. Forty of the forty-four units receive Project-Based Vouchers (PBV) funding and the Housing Assistance Program (HAP) contract is paying as expected. Staff continue with weekly all-hands meetings and task coordination during the



project's transition to property operations.

LifeSTEPS continues to provide ongoing intensive case management, resident engagement, and other supportive services. LifeSTEPS receives intensive case management funding from the County of Alameda and files detailed reports on those activities. LifeSTEPS held several resident events with tenants from both properties recently to celebrate the holidays and new year.

#### Stabilization and Permanent Financing

The Estuary I has a draft version of the cost certification under review by the investor. The project continues to move forward with stabilized operations, including achieving key milestones such as 100% of all tax credit units leased by December 15, 2025 (Met), three full months of 95% occupancy (Met) and working to meet operations at a 1.10 debt service coverage ratio (this is a ratio that compares income to expenses) by May 1, 2026 (Under review), and all financial close out documentation such as the final cost certification by June 1, 2026.

The project received its 2025-2026 Welfare exemption for property taxes and staff submitted for the 2026-2027 exemption in February. Staff received the \$16M second capital contribution for the project, which paid down the construction loan and saved significant interest that would have been paid without this money. Staff will submit the third capital contribution request during the loan conversion. The Placed in Service package is drafted and undergoing internal review before being submitted to the CA Tax Credit Allocation Committee (CTCAC) for acceptance in accordance with the requirements of the project's conversion, which is anticipated in July 2026.

#### Warranty

The project entered the warranty period in August 2025 and will be under warranty for twelve months. During this time, all warranty items have been minor and expediently resolved by the general contractor. Warranty issues are performed at no cost to the property.

In December 2025, staff released the performance bond on file with the city in regard to the offsite work for Mabuhay. A warranty bond is now on file with the city and will be released in the fall of 2026. The offsite portions of North Housing Block A also had an East Bay Municipal Utility District (EBMUD) performance bond in regard to the main water extensions. A sign-off walk was conducted on December 31, 2025, and all work generated via a punch list during the walk was completed by the general contractor J.H. Fitzmaurice. EBMUD is currently completing internal processes and will issue contract acceptance to the Housing Authority.

#### Awards/Recognitions

Staff prepared nominations for both Linnet Corner and Estuary I for regional and national awards. Award announcements will be made by the various agencies in early summer through the fall.

#### **FISCAL IMPACT**

AHA and ICD have completion and lease-up guarantees on this development. The construction was completed one month early and under budget. Operations and lease up activities are currently meeting project milestones.



**CEQA**

Not Applicable.

**RECOMMENDATION**

Accept the Quarterly Stabilization Report for The Estuary I.

**ATTACHMENTS**

None

Respectfully submitted,



Jocelyn Layte, Associate Project Manager



# ISLAND CITY DEVELOPMENT

Fax (510) 522-7848 | TTY/TRS 711

To: Board of Directors  
Island City Development

From: Sylvia Martinez, Director of Housing Development

Date: May 20, 2026

Re: Accept the Quarterly Development Report for The Estuary II.

## **BACKGROUND**

Estuary II is the third development in North Housing Block A at the former Alameda Naval Air Station (NAS). Estuary II is expected to have 46 units of permanent supportive housing for formerly homeless households. The Housing Authority of the City of Alameda (AHA) is leading the development of a homeless accommodation conveyance, alongside partners Alameda Point Collaborative and Building Futures. Island City Development (ICD) is the developer.

Estuary II was designed and planned as a condominium project to Estuary I (now in operation) for vertical construction on vacant land. The building permit is ready to be issued upon payment of the building permit fees.

Please see previous Board reports for project details before this month's update.

## **DISCUSSION**

Estuary II continues to need its final tax credits and/or bonds which are the final and largest financing pieces. The development has been applying for this funding for the past two years. Recent updates include:

In March, staff applied for a new award from the Federal Home Loan Bank of San Francisco (FHLB) and expects to be notified in June. In April, staff applied for HOME funds from the City of Alameda, and expects to be notified in June. Staff is currently planning for a July tax credit round.

In January, AHA received notice that the State of California Housing and Community Development department (HCD) would be willing to extend its commitment of National Housing Trust Funds (almost \$10 million dollars in soft funding) for one more year. Staff is working with HCD to update the Standard Agreement to accept this extension and to ascertain if additional funding may be available to support this project.

Staff has begun a review with the architect of any change orders from Estuary I that could be implemented at Estuary II. This activity may include an upgrade to current building code for some electrical and mechanical areas.



**FISCAL IMPACT**

The total pre-development loan from Alameda Affordable Housing Corporation (AAHC)/AHA available for the Estuary II project is \$3,750,000. Funds are disbursed to ICD on an as-needed basis. Of this amount, 97% has been spent on the on and offsite improvements and other related costs. Please refer to the attached chart summarizing expenses through March 30, 2026.

**CEQA**

Not applicable.

**RECOMMENDATION**

Accept the Quarterly Development Report for The Estuary II.

**ATTACHMENTS**

1. PSH II Costs through March 31 2026

Respectfully submitted,



Sylvia Martinez, Director of Housing Development

Predevelopment Expenses Chart Through March 31, 2026

The Estuary II	Uses	Sources
Predevelopment loan funds (AAHTF) available for the Estuary II project		\$3,750,000
AHA funded site preparation costs as the master developer for the pro rata share costs of ground improvement and offsite improvement for Estuary II. *Shown for informational purposes only		\$1,500,000
Predevelopment expenses to-date includes predevelopment costs, pro rata shares of master plan, demolition, and land carrying costs)	\$3,640,835	
Soil Off Haul Costs - Estuary II's Pro Rata Share	\$285,859	
Predevelopment Funds Remaining	\$1,323,306	
Cumulative Total AHA Funds for Estuary II		\$5,250,000



**ISLAND CITY DEVELOPMENT**

Fax (510) 522-7848 | TTY/TRS 711

To: Board of Directors  
Island City Development

From: Sylvia Martinez, Director of Housing Development

Date: May 20, 2026

Re: Accept the Quarterly Report for The Poplar.

**BACKGROUND**

The Housing Authority of the City of Alameda (AHA) purchased the property (the Site) at 2615 Eagle Avenue in March 2022. AHA has a goal of serving 50-60 families with affordable housing, with up to 25% supportive housing apartments if required by funding sources. The development will have a preference for Alameda Unified School District (AUSD) staff, as well as a live/work preference for Alamedans.

In December 2023, the Board entered into \$3.4 million pre-development loan from Capital Impact Partners Bay's Future Fund (BFF) to fund the acquisition and pre-development of this site for up to four years. In February 2024, the Board approved a \$2.1 million pre-development loan from the Reserve Policy to supplement the BFF loan amount. In March 2024, the Board approved an option to ground lease with a 20-year term to Island City Development (ICD).

AHA has received redevelopment funding from the City of Alameda totaling \$4,888,053. AHA has recently received an additional \$1,000,000 from the City of Alameda increasing this redevelopment funding total to \$5,888,053.

In March 2024, the project was awarded \$534,565 in Equitable Community Revitalization Grant (ECRG) funds from the Department of Toxic Substances Control Office of Brownfields (DTSC). The grant has a two-year term: March 2024 to March 2027 (per recent extension). The majority of the ECRG grant is slated for environmental investigation and the development of a remedial action plan.

Please see previous Board Reports for project details prior to this month's update.

**DISCUSSION**

In December 2025, Rincon conducted seasonal testing, and the results have been published on the public website Geotracker (<https://geotracker.waterboards.ca.gov/>). Staff requested and received an extension to 2027 to re-submit the Corrective Action Plan (CAP) from the Water Board.

AHA has installed a new fence to the legal property line. Pest control and weekly site walks



continue. Staff have also hired a local consultant who will be working on the website and other communications in the next months.

Pre-development expenses to date are attached. Staff is preparing an updated pre-development budget for 2026-2027. Activities focus on continuing the entitlement process and ongoing design. An interest list is available for prospective tenants.

**FISCAL IMPACT**

Pre-development expenses at The Poplar are currently being funded by City redevelopment funding and the Capital Impact BFF loan. Environmental-specific costs are being reimbursed through the ECRG grant.

**CEQA**

Not Applicable.

**RECOMMENDATION**

Accept the Quarterly Development Report for the Poplar.

**ATTACHMENTS**

1. Poplar Predev Spent to Date\_260330

Respectfully submitted,



Sylvia Martinez, Director of Housing Development

**The Poplar Predevelopment Spent to Date**

As of 4/15/26

Project Administration	\$	445,122		
Engineering	\$	63,184		
Design	\$	160,158		
Environmental	\$	360,115		
Prepaid deposits	\$	656,314		
Financial	\$	223,688		
Holding Costs	\$	128,066		
		<u>\$</u>	<u>2,036,646</u>	
Sub-Total				
Acquisition			<u>\$</u>	<u>2,520,807</u>
TOTAL			<u>\$</u>	<u>4,557,453.</u>



**ISLAND CITY DEVELOPMENT**

Fax (510) 522-7848 | TTY/TRS 711

To: Board of Directors  
Island City Development

From: Nancy Gerardin, Director of Property Operations

Date: May 20, 2026

Re: Approve the Quarterly Write-off, to March 31, 2026, of Uncollectible Accounts Receivable from Former Residents.

**BACKGROUND**

Periodically, the Housing Authority of the City of Alameda (AHA) or its affiliates, Alameda Affordable Housing Corporation (AAHC) and Island City Development (ICD), write-off uncollectible rent and miscellaneous charges from its resident ledgers. The term "write-off" indicates a procedure where past-due amounts from residents who are no longer residents in an AHA, AAHC, or ICD community, are removed from the resident ledgers after the usual means of collection have been exhausted. This procedure does not preclude the AHA, AAHC, or ICD from continuing to pursue collection through a collection agency or other legal actions. Future collection of amounts previously written-off will reduce these expenses.

**DISCUSSION**

This request is to write-off accounts receivable for residents who have voluntarily vacated, passed, or were evicted and had outstanding balances due to the Alameda Affordable Housing Corporation, the Housing Authority of the City of Alameda, and Island City Development. A final notice will be sent to the respective resident(s) before the outstanding balance is written off. The total amount to be written off is \$136,205.70 and presented in the attachment to this memorandum. This amount is a combination of past rents due, late fees, damages, and miscellaneous maintenance charges.

**FISCAL IMPACT**

This resident account write-off will result in an expense to the Alameda Affordable Housing Corporation of \$78,335.74, Housing Authority of the City of Alameda of \$680.00, and ICD of \$57,189.96.

**CEQA**

N/A

**RECOMMENDATION**

Approve the Quarterly Write-off to March 31, 2026, of Uncollectible Accounts Receivable from Former Residents.



**ATTACHMENTS**

1. BOC Attachment - Q1 2026 Write Off 05.20.2026

Respectfully submitted,



Nancy Gerardin, Director of Property Operations

Legal Entity	Property Name	Reason for Move Out	Move Out Date	Amount of Bad Debt per reconciliation
AAHC	China Clipper	Relocation	1.7.2026	\$7,825.00
AAHC	Parrot Village	Relocation	2.21.2026	\$3,876.00
AAHC	Parrot Village	Relocation	2.11.2026	\$8,195.51
AAHC	Eagle Village	Death	2.9.2026	\$283.00
AAHC	Eagle Village	Relocation	3.9.2026	\$35,014.92
AAHC	Eagle Village	Relocation	3.9.2026	\$22,242.31
AAHC	AAHC Scattered Sites	Relocation	12.24.2025	\$899.00
			<b>TOTAL AAHC</b>	<b>\$78,335.74</b>
ICD	Estuary	Death	11.25.2025	\$3,143.00
	Rosefield Village	Eviction	2.25.2026	\$54,046.96
			<b>TOTAL ICD</b>	<b>\$57,189.96</b>
AHA	Independence Plaza	Death	1.16.2026	\$680.00
			<b>TOTAL AHA</b>	<b>\$680.00</b>
			<b>TOTAL</b>	<b>\$136,205.70</b>

ENTITY	Q4 2025 Bad Debt	Q3 2025 Bad Debt	Q2 2025 Bad Debt	Q1 2025 Bad Debt
AAHC	\$40,312.00	\$43,777.10	\$40,862.05	\$96,012.88
ICD	\$516.00	\$72,783.97	\$38,802.57	\$92,364.77
AHA	\$0.00	\$680.00	\$8,378.72	\$13,972.00
	<b>\$40,828.00</b>	<b>\$117,241.07</b>	<b>\$88,043.34</b>	<b>\$202,349.65</b>



# ISLAND CITY DEVELOPMENT

Fax (510) 522-7848 | TTY/TRS 711

ITEM 5.H

To: Board of Directors  
Island City Development

From: Radha Mehta, Management Analyst

Date: May 20, 2026

Re: Ratify the AHA Board of Commissioners' Decision to Authorize the Executive Director to Execute a Consultant Services Agreement between the Housing Authority of the City of Alameda and Aleshire & Wynder, LLP for General Counsel services with a maximum contract amount not to exceed \$250,000 for a three-year term, with two 1-year options.

## **BACKGROUND**

As a public agency, the Housing Authority of the City of Alameda (AHA) is required to obtain general counsel services. Under AHA's procurement policy and procedures, in compliance with HUD guidelines, it is preferable to enter into a multi-year contract for ongoing general counsel services. The proposed contract may also include items billed to ICD.

## **DISCUSSION**

On February 10, 2026, staff issued a Request for Proposals (RFP) for Legal Services. AHA received 12 proposals from legal firms, including Aleshire & Wynder, LLP. In the proposals, the firms selected the following counsel roles to provide: General Counsel, Fair Housing Counsel, Real Estate Counsel, Procurement and Insurance Counsel, Conflict of Interest Counsel, and Housing Programs Counsel. The Evaluation Committee reviewed and ranked the proposals and the firms with the experience in General Counsel services were selected to interview with the Committee. The interview panel was composed of AHA staff and the Housing Authority of County of Alameda's Deputy Executive Director. This panel interviewed four firms on May 1, 2026: 1. Aleshire & Wynder, LLP (A&W) 2. Reno & Cavanaugh LLP 3. Burke Williams Sorenson, LLP and 4. Burns Law Group. The proposals and interview notes were also reviewed by a Board Member. A&W was ranked first by the panelists for General Counsel services. A&W's presentation is attached to this memorandum.

Staff recommends contracting with A&W to provide as-needed General Counsel services, with Adrian R. Guerra serving as General Counsel. A&W has worked with numerous public agencies, such as housing authorities, local agencies, and other public entities. The firm has extensive experience advising the governing bodies of public agencies, providing legal guidance on issues involving the Brown Act, the California Public Records Act, conflicts of interest, and parliamentary procedure. During Adrian RZ. Guerra's roles as General Counsel and Special Counsel for housing authorities, he has worked extensively with the Housing Choice Voucher and Public Housing programs, complaints filed with the U.S. Department of



Housing and Urban Development and the California Civil Rights Department, and he also serves as a hearing officer in hearings to challenge housing authority administrative decisions. Their offices are located in Irvine, Los Angeles, Riverside, Fresno, and Oakland, and they have provided legal services since 2003.

The price proposal includes a flat hourly rate for routine legal services, as well as costs associated with tasks beyond the routine scope of services. Proposed hourly rates are inclusive of employee wages and benefits, clerical support, overhead and profit, licensing, insurance, materials, and telephone calls. Out-of-pocket expenses such as document production, mileage reimbursements, or fees required by third parties such as application fees, filing fees or delivery charges will be reimbursed to A&W at actual cost. Travel between attorney offices (Irvine, Los Angeles, Fresno, Bay Area, or San Diego) and the Agency’s office will be limited to a maximum of 2.5 hours each way, billed at a rate of \$250 per hour. Travel within Alameda County for attendance at in-person meetings, court appearances, depositions, administrative hearings, or other meetings and appearances will be billed based on actual travel time each way at a rate of \$250 per hour.

Hourly rates for the firm are as follows:

<b>Aleshire &amp; Wynder, LLP</b>	<b>Position</b>	<b>Hourly Fee YR 1</b>	<b>Hourly Fee YR 2</b>	<b>Hourly Fee YR 3</b>	<b>Hourly Fee YR 4</b>	<b>Hourly Fee YR 5</b>
<b>General Counsel Services</b>	Partners	\$340	\$350	\$360	\$370	\$380
	Senior Associates.	\$320	\$330	\$340	\$350	\$360
	Associates	\$300	\$310	\$320	\$330	\$340

**FISCAL IMPACT**

The Housing Authority's budget includes funding for general counsel services for the current fiscal year. Future budgets will incorporate sufficient funds for services rendered during the remainder of the agreement’s initial three-year term and additional two-year term, if the Board chooses to extend the term of the agreement.

**CEQA**

Not applicable.

**RECOMMENDATION**

Ratify the AHA Board of Commissioners' Decision to Authorize the Executive Director to Execute a Consultant Services Agreement between the Housing Authority of the City of Alameda and Aleshire & Wynder, LLP for General Counsel services with a maximum contract amount not to exceed \$250,000 for a three-year term, with two 1-year options.

**ATTACHMENTS**

1. Aleshire & Wynder General Counsel Presentation
2. Aleshire & Wynder - Draft General Counsel Agreement



Respectfully submitted,

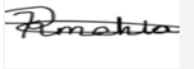

Radha Mehta, Management Analyst

# Aleshire & Wynder, LLP

---

Housing Authority of the City of Alameda

Proposed General Counsel

May 20, 2026

# Adrian R. Guerra, Esq.

## Proposed General Counsel

---

- Education
  - BS, University of Southern California, 1996
  - JD, Boston College Law School, 2000
- Equity Partner and on Management Team of A&W
- Current Positions
  - General Counsel for the Santa Clara County Housing Authority
  - City Attorney for the Cities of Irwindale, Grand Terrace, and La Cañada Flintridge
  - Special Counsel for the Housing Authority of the City of Alameda, Los Angeles County Development Authority, and Housing Authority of the City of Los Angeles



# Michelle Hernandez, Esq.

## Assistant General Counsel

---

- Education

- UC Law San Francisco (formerly UC Hastings), San Francisco, JD, 2017
- University of California, San Diego, BA, 2011

- Current Positions

- Deputy City Attorney for the Cities of Cupertino, Yuba City, Sanger, Madera and Irwindale

- Practice Areas

- Land Use & Zoning
- Public Contracts
- Utilities / Energy
- Housing
- Public Finance
- Real Estate / Title
- Telecommunications
- Water



# Jamie Traxler, Esq.

## Deputy General Counsel

---

- Education

- Chapman University Dale E. Fowler School of Law, JD, 2019
- Arizona State University, BA, Magna Cum Laude, 2015

- Current Positions

- Assistant City Attorney for the Cities of Irwindale and Grand Terrace
- General Counsel of Isla Vista Community Services District

- Practice Areas

- Land Use & Zoning
- Public Contracts
- Housing
- Labor & Employment
- Litigation & Appellate Law
- First Amendment/Constitutional Law
- Unlawful Detainer



# One Firm, Fully Integrated Support

When you hire A&W you don't just get the attorneys list – you gain the strength of our entire firm

---



7 Locations: Irvine, Los Angeles, Riverside, Fresno, Oakland, Westlake Village and San Diego



75 Attorneys ranging from Equity Partners, Partners, Of Counsel, Senior Associates and Associates



5 Paralegals and over 40 Support Staff

Our Oakland office is home to specialists in environmental, labor & employment, public contracts, housing, land use and more.

# One Stop Shop General Counsel to Public Agencies

## General

- Land Use & Zoning
- General Litigation
- Constitutional Issues
- Service Contracts
- Public Works Contracts
- Brown Act
- Public Records
- Conflicts of Interest
- Franchises
- Refuse
- Fees and Taxes
- Risk Management
- Real Estate

## Specialty

- Economic Development
- Successor Agencies/Redevelopment and Housing
- Eminent Domain
- Toxic and Hazardous Waste
- Utilities (Energy, Waste, Sanitation)
- CEQA and Endangered Species
- Public Finance
- Election Law
- Code Enforcement
- Marijuana
- Water
- Education
- Mobile Home Parks
- Prevailing Wage Law Compliance
- Labor & Employment

# Role of the General Counsel

---

- Do not determine policy
- Advise on the law
- Provide options and strategy
- Connect the dots with the big picture in mind...spotting issues
- Keep the client up to date on projects and on applicable law
- Be available and easy to communicate with



# General Counsel to Public Agencies

---

Brown Act &  
Parliamentary  
Procedure

Conflicts of  
Interest

Public  
Records Act &  
Freedom of  
Information  
Act

Contract &  
Procurement

Planning,  
Zoning &  
CEQA

# Implementation of Governing Federal Regulations

---

- Provided legal analysis of federal regulations governing public housing and Section 8 programs
- Advised LACDA on implementation of federal regulations through ACOP for public housing
- Advised LACDA and Santa Clara County Housing Authority regarding Administrative Plan for Section 8/HCV Program

# Section 8 Terminations

---

Advise

Advised on whether sufficient evidence exists to terminate Section 8 assistance in accordance with federal regulations and Administrative Plan

Represent

Represented LACDA in various informal hearings as part of termination process

Defend

Defended LACDA and SCCHA in writ of mandamus proceedings challenging client decisions

# Hearing Officer for the Alameda Housing Authority

Termination of  
HCV Assistance

Denials of  
Reasonable  
Accommodation  
Requests

Fraud Cases

Program Actions -  
Downsizing  
Voucher  
Size/Reduction of  
Payment  
Standards

# Defense Against HUD/CA Civil Rights Dept. Discrimination Complaints

Experience regarding Civil Rights Act of 1964, Rehabilitation Act, Fair Housing Act, FEHA, ADA

Defend complaints filed with HUD and FEHA whereby Section 8 participants or Public Housing tenants allege discrimination by the Housing Authority

Examples of allegations include denial of reasonable accommodation requests, mistreatment or wrongdoing by staff, and failure to implement policies fairly

Need to ensure that HUD/FEHA understand background of case and not let the complainant steer the investigation

# Client Training

---

- Trained client staff on Contracts, Public Records Act, and Conflicts of Interest
- Trained LACDA hearing officers regarding how to conduct informal hearings
- Trained LACDA Section 8 staff regarding fair housing, applicable discrimination laws, reasonable accommodation procedures and analysis, LEP, VAWA
- Trained AHA Staff regarding informal hearing process



# Why our Firm and Team Partners Well with AHA

---

- Our firm is 100% dedicated to public agencies
  - Rates will be lower than private client firms
  - We can provide a one-stop shop for all legal issues pertaining to a housing authority
  - We bring viewpoints from other public agencies on common public agency issues
- We combine knowledge and experience serving as general counsel and providing substantive housing law experience
- Our team is easy to work with, accessible, and structured to get the work assigned to the right person for a quicker response and in the least costly way



# How Our Firm Furthers the Mission of Our Clients

---



- Keeping the client up to date with new laws and regulations
- Understanding the national, state and local issues that may affect the agency
- Participating in or contributing towards events conducted by the agency for their community

# Mission Statement: 7 Core Values

---

OUR MISSION IS TO DELIVER TO OUR CLIENTS THE FOLLOWING:

- ❖ Expertise
- ❖ Focus and Timeliness
- ❖ Creativity
- ❖ Accountability
- ❖ Cost Control
- ❖ Integrity and Impartiality
- ❖ Commitment

Our 20+ year relationships with our public clients are continuing testimony to our long-term successful achievement of this mission.

# Thank You



Aleshire & Wynder

**CONSULTANT SERVICES CONTRACT**

**THIS CONSULTANT SERVICES CONTRACT** ("Agreement"), entered into this May 21, 2026 ("Effective Date"), by and between the HOUSING AUTHORITY OF THE CITY OF ALAMEDA, a public body corporate and politic (hereinafter referred to as "AHA"), and Aleshire & Wynder, LLP a California Limited Liability Partnership located at 1 Park Plaza, Suite 1000, Irvine, CA 92614 (hereinafter referred to as "Consultant"), is made with reference to the following:

**RECITALS:**

A. AHA is a Housing Authority duly created, established, and authorized to transact business and exercise its powers, all under and pursuant to the provisions of the Housing Authorities Law which is Part 2 of Division 24 of the California Health and Safety Code commencing with Section 34200 et seq.

B. Pursuant to the Housing Authorities Law, AHA is authorized to make and execute contracts and other instruments necessary or convenient to exercise its powers.

C. AHA has determined that it requires professional services for General Counsel services.

D. Consultant is specially trained, experienced, and competent to perform the special services which will be required by this Agreement.

E. Consultant represents that it possesses the skill, experience, ability, background, applicable certification and knowledge to provide the services described in this Agreement on the terms and conditions described herein.

F. AHA and Consultant desire to enter into an agreement to provide the subject services as discussed in more detail below.

NOW, THEREFORE, in consideration of performance by the parties of the promises, covenants, and conditions herein contained, the parties hereto agree as follows:

1. **TERM.**

The term of this Agreement shall commence on the Effective Date and end on April 30, 2029, unless extended, as discussed herein, or terminated earlier as provided in Paragraph 20 below ("Term"). The parties may choose by mutual agreement to extend the term of this Agreement up to a maximum of 60 months (5 years total) and shall do so by executing a written amendment to the Agreement. All indemnification and hold harmless provisions in this Agreement shall survive the termination of this Agreement.

2. **SERVICES TO BE PERFORMED.**

2.1 Consultant shall provide the following services to AHA, (i) those services outlined and specified in the Scope of Services attached hereto as Exhibit A and

incorporated herein by this reference; and (ii) those services outlined and specified in Consultant's accepted bid proposal attached hereto as Exhibit B and incorporated herein by this reference, all at the not to exceed fee stated in Paragraph 3 below. In the event of any inconsistencies between Consultant's accepted bid proposal and this Agreement, the terms of this Agreement shall govern.

2.2 Consultant represents that it has the skills, experience, and knowledge necessary to fully and adequately perform under this Agreement, and AHA relies upon this representation. Consultant shall perform pursuant to the terms of this Agreement, and Consultant shall perform the services and duties in conformance to and consistent with the standards generally recognized as being employed by professionals in the same discipline in the State of California. Consultant further represents and warrants to AHA that it has all licenses, permits, qualifications and approvals of whatever nature are legally required to practice its profession. Consultant further represents that it shall keep all such licenses and approvals in effect during the Term of this Agreement.

2.3 Consultant affirms that it is fully apprised of all of the work to be performed under this Agreement; and Consultant agrees it can properly perform this work for the fee stated in Paragraph 3. Consultant shall not be liable or obligated to perform Services in excess of the fee stated in Paragraph 3. Consultant shall not perform services or provide products that are not set forth in this Agreement, unless by prior written request of AHA.

2.4 Consultant agrees to perform all services in accord with this Agreement in a manner commensurate with the prevailing standards of like professionals in the San Francisco Bay Area and agrees that all services shall be performed by qualified and experienced personnel who are not employed by the AHA nor have any contractual relationship with AHA.

2.5 Acceptance by AHA of Consultant's performance under this Agreement does not operate as a release of Consultant's responsibility for full compliance with the terms of this Agreement.

2.6 Fidelity Bond: If Consultant, its officers, employees, subcontractors, agents, volunteers, or representatives interact with money or securities in or arising out of the performance of this Agreement, Consultant shall maintain a fidelity bond that fulfills the following requirements.

AHA must be designated as the obligee, and Consultant as the principal.

Consultant's fidelity bond must be for a minimum of the sum of the gross potential rental income for two months plus the amount of the security deposits for property management services.

Consultant's fidelity bond must provide blanket coverage that includes Consultant and all its officers, employees, subcontractors, agents, volunteers, or representatives who may have access to money and securities arising out of or in connection with the Consultant's performance of this Agreement.

The bond shall cover losses including, without limitation, those arising from forgery or alteration, computer fraud, funds transfer fraud, counterfeit money and money orders, burglary, robbery, theft, embezzlement, employee dishonesty, and misplacement of money and securities.

The bond shall not contain a condition requiring arrest and conviction.

Prior to the commencement of the work, Consultant shall deliver to AHA an assurance letter, or similar documentation, from the bonding company or agency declaring the type of bond, the obligee (AHA) and principal (Consultant), amount of coverage, coverage period, and the annual cost of the bond.

### 3. **COMPENSATION TO CONSULTANT.**

3.1 AHA shall pay the Consultant for services performed, products provided and expenses incurred for the Scope of Services defined in Exhibit A, and according to the Fee Schedule set forth in Exhibit B. Maximum payment by AHA to Consultant for the services provided herein shall not exceed Two Hundred Fifty Thousand Dollars(\$250,000), including all expenses("Contracted Amount"). AHA shall not be responsible for any fees or costs incurred above or beyond the aforementioned Contracted Amount and AHA shall have no obligation to purchase any specified amount of services or products, unless agreed to in writing by AHA pursuant to Paragraph 4 below. Consultant shall invoice AHA for the services performed pursuant to the Scope of Services attached hereto as Exhibit A, at the rates, inclusive of all taxes, insurance, benefits, wages, profit, overhead, and every other personnel cost borne by Consultant, set forth in the Scope of Services attached hereto as Exhibit A; provided, however, in no event shall any and all costs paid under this Agreement exceed the Contracted Amount. Consultant shall not be liable or obligated to perform Services in excess of the fee stated in this section.

3.2 CONSULTANT shall be paid only in accordance with an invoice submitted to AHA by Consultant. AHA shall pay the invoice within thirty (30) working days from the date of receipt of the invoice. Payment shall be made to Consultant only after services have been rendered and Consultant's candidate has accepted an offer that has been made by AHA. For this Agreement, invoices can be submitted by email to primary contact (below) with a copy to [accountspayable@alamedahsq.org](mailto:accountspayable@alamedahsq.org) or on the AHA's vendor portal.

Housing Authority of the City of Alameda  
701 Atlantic Avenue  
Alameda, CA 94501-2161  
ATTN: Vanessa Cooper  
(510) 747-4320

Email: [vcooper@alamedahsg.org](mailto:vcooper@alamedahsg.org)

Each invoice shall contain a minimum of the following information: invoice number and date; remittance address; itemization of the description of the work performed, the date of performance, the associated time for completion; and an invoice total.

All contracts over \$5,000 are required to be paid via Electronic Funds Transfer (EFT)/Automated Clearing House (ACH) disbursements. The required forms can be found on the website or by contacting Finance at 510-747-4315.

### 4. **ALTERATION OR CHANGES TO THE AGREEMENT.**

No alteration or variation of the terms of this Agreement shall be valid unless made in writing and signed by the parties hereto, and no oral understanding or agreement not incorporated herein shall be binding on any of the parties hereto. No additional services

shall be performed by Consultant without a written amendment to this Agreement.

Consultant understands that AHA's Board of Commissioners, Executive Director, or designee, within their delegated authority, are the only authorized AHA representatives who may at any time, by written order, make any alterations within the general scope of this Agreement.

5. **INSPECTION OF SERVICES.**

All performances under this Agreement shall be subject to inspection by AHA. Consultant shall provide adequate cooperation to AHA representatives to permit him/her to determine Consultant's conformity with the terms of this Agreement.

Consultant shall permit an AHA representative to monitor, assess or evaluate Consultant's performance under this Agreement at any time upon reasonable notice to Consultant.

6. **TIME IS OF THE ESSENCE.**

Consultant and AHA agree that time is of the essence regarding the performance of this Agreement.

7. **INDEPENDENT CONTRACTOR.**

The Consultant is, for purposes relating to this Agreement, an independent contractor and shall not be deemed an employee of AHA. It is expressly understood and agreed that the Consultant (including its employees, agents and subcontractors) shall in no event be entitled to any benefits to which AHA's employees are entitled, including but not limited to overtime, any retirement benefits, injury leave or unemployment insurance, workers' compensation coverage, vacation, and/or sick leave. Deductions shall not be made for any state or federal taxes, FICA payments, PERS payments, or other purposes normally associated with an employer-employee relationship from any fees due Consultant. Payments of the above items, if required, are the responsibility of Consultant.. No right of employment will be acquired by virtue of Consultant's services. There shall be no employer-employee relationship between the parties; and Consultant shall hold AHA harmless from any and all claims that may be made against AHA based upon any contention by a third party that an employer-employee relationship exists by reason of this Agreement.

AHA and Consultant agree that during the term of this Agreement and for a period of one year after termination, the parties shall not solicit for employment, hire, or retain, whether as an employee or independent contractor, any person who is or has been employed by the other without written agreement by the other party.

8. **IMMIGRATION REFORM AND CONTROL ACT (IRCA).**

Consultant assumes any and all responsibility for verifying the identity and employment authorization of all of its employees performing work hereunder, pursuant to all applicable IRCA or other federal or state rules and regulations. Consultant shall indemnify and hold AHA harmless from and against any loss, damage, liability, costs or expenses arising from any noncompliance of this provision by Consultant.

9. **NON-DISCRIMINATION.**

Consistent with AHA's policy that harassment and discrimination are unacceptable conduct and will not be tolerated, Consultant shall not be discriminate in the provision of services, allocation of benefits, accommodation in facilities, or employment of personnel on the basis of ethnic group identification, race, religious creed, color, national origin, ancestry, physical handicap, medical condition, sexual orientation, pregnancy, sex, age, gender identity, or marital status in the performance of this Agreement; and, to the extent they shall be found to be applicable hereto, shall comply with the provisions of the

California Fair Employment Practices Act (commencing with Section 1410 of the Labor Code), the Federal Civil Rights Act of 1964 (P.L. 88-352), the Americans with Disabilities Act of 1990 (42 U.S.C. S1210 et seq.) and all other applicable laws or regulations. Consultant agrees that any and all violations of this provision shall constitute a breach of this Agreement.

10. **INDEMNIFICATION/HOLD HARMLESS.**

10.1 To the fullest extent permitted by law, Consultant agrees to indemnify and hold harmless, including the cost to defend, the Housing Authority of the City of Alameda, its affiliates Alameda Affordable Housing Corporation and Island City Development, their respective directors, officers, Board of Commissioners, Board of Directors, elected and appointed officials, employees, volunteers, agents, and representatives (individually and collectively hereinafter referred to as "Indemnitees") from and against any and all liability, claims, losses, damages, or expenses, including reasonable attorney's fees, that arise out of, or pertain to, or relate to the negligence, recklessness, or willful misconduct of Consultant, its officers, employees, subcontractors, independent contractors, agents, or representatives in the performance of services under this contract. This indemnity does not apply to liability for damages arising from the sole negligence or willful acts of Indemnitees. This duty to indemnify shall not be waived or modified by contractual agreement or acts of the parties.

10.2 With respect to any action or claim subject to indemnification herein by Consultant, Consultant shall, at their sole cost, have the right to use counsel of their own choice and shall have the right to adjust, settle, or compromise any such action or claim without the prior consent of AHA, provided, however, that any such adjustment, settlement or compromise in no manner whatsoever limits or circumscribes Consultant's indemnification to Indemnitees as set forth herein. Consultant's obligation hereunder shall be satisfied when Consultant has provided to AHA the appropriate form of dismissal relieving AHA from any liability for the action or claim involved.

10.3 AHA does not, and shall not, waive any rights that it may possess against Consultant because of acceptance by AHA, or the deposit with AHA, of any insurance policy or certificate required pursuant to this Agreement. This hold harmless, indemnification and defense provision shall apply regardless of whether or not any insurance policies are determined to be applicable to the claim, demand, damage, liability, loss, cost, or expense.

10.4 These defense and indemnity obligations shall survive the termination and expiration of this Agreement and are independent of and not in any way limited by the insurance requirements of this Agreement.

11. **INSURANCE.**

Without limiting or diminishing the Consultant's obligation to indemnify, defend, and hold AHA harmless, Consultant shall procure and maintain, or cause to be maintained, at its sole cost and expense, insurance coverage in compliance with Exhibit C on or before the commencement of the terms of this Agreement.

**12. CONFLICT OF INTEREST.**

No employee, agent, contractor, officer or official of AHA who exercises any functions or responsibilities with respect to this Agreement or who is in a position to participate in a decision-making process or gain inside information with regard to it, shall obtain a personal or financial interest in or benefit from any contract, subcontract or agreement with respect thereto, or the proceeds thereunder, either for himself or herself or for those with whom they have family or business ties, during his or her tenure or for one (1) year thereafter. The term "contractor" also includes the employees, officers (including board members), agents and subcontractors of Consultant under this Agreement.

Consultant covenants that it presently has no interest, including, but not limited to, other projects or contracts, and shall not acquire any such interest, direct or indirect, which would conflict in any manner or degree with Consultant's performance under this Agreement. Consultant further covenants that no person or subcontractor having any such interest shall be employed or retained by Consultant under this Agreement. Consultant agrees to inform AHA of all Consultant's interests, if any, which are or may be perceived as incompatible with the AHA's interests.

Consultant shall not, under circumstances which could be interpreted as an attempt to influence the recipient in the conduct of his/her duties, accept any gratuity or special favor from individuals or firms with whom Consultant is doing business or proposing to do business, in accomplishing the work under this Agreement.

Consultant or its employees shall not offer gifts, gratuity, favors, and entertainment directly or indirectly to AHA employees.

In order to carry out the purposes of this section, Consultant shall incorporate, or cause to be incorporated, in all contracts and subcontracts relating to activities pursuant to this Agreement, a provision similar to that of this section.

Consultant warrants that it is not a conflict of interest for Consultant to perform the services required by this Agreement. Consultant further understands that it may be required to fill out a Statement of Economic Interests, a form provided by the California Fair Political Practices Commission, if the services provided under this Agreement require Consultant to make certain governmental decisions or serve in a staff capacity as defined in Title 2, Division 6, Section 18700 of the California Code of Regulations.

**13. PROHIBITION AGAINST ASSIGNMENTS.**

Consultant shall not assign, sublease, hypothecate, or transfer this Agreement or any interest therein directly or indirectly, by operation of law or otherwise without prior written consent of AHA. Any attempt to do so without said consent shall be null and void, and any assignee, sub lessee, hypothecate or transferee shall acquire no right or interest by reason of such attempted assignment, hypothecation or transfer. However, claims for money by Consultant from AHA under this Agreement may be assigned to a bank, trust company or other financial institution without prior written consent, but written notice of such assignment shall be promptly furnished to AHA by Consultant.

The sale, assignment, transfer or other disposition of any of the issued and outstanding capital stock of Consultant, or of the interest of any general partner or joint venturer or syndicate member or cotenant if Consultant is a partnership or joint venture or syndicate or co tenancy, which shall result in changing the control of Consultant, shall be

construed as an assignment of this Agreement. Control means fifty percent (50%) or more of the voting power of the corporation.

14. **SUBCONTRACTOR APPROVAL.**

Unless prior written consent from AHA is obtained, only those people and subcontractors whose names are attached to this Agreement shall be used in the performance of this Agreement. In the event that Consultant employs subcontractors, such subcontractors shall be required to furnish proof of worker's compensation insurance and shall also be required to carry general, automobile and professional liability insurance in reasonable conformity to the insurance carried by Consultant. In addition, any work or services subcontracted hereunder shall be subject to each provision of this Agreement.

15. **PERMITS AND LICENSES.**

Consultant shall comply with all State or other licensing requirements, including but not limited to the provisions of Chapter 9 of Division 3 of the Business and Professions Code. All licensing requirements shall be met at the time proposals are submitted to AHA, including, but not limited to a City of Alameda business license. Consultant warrants that it has all necessary permits, approvals, certificates, waivers and exemptions necessary for performance of this Agreement as required by the laws and regulations of the United States, the State of California, the County of Alameda, the City of Alameda and all other governmental agencies with jurisdiction, and shall maintain these throughout the term of this Agreement relative to the Scope of Services to be performed under Exhibit A, and that service(s) will be performed by properly trained and licensed staff.

16. **REPORTS.**

Each and every report, draft, work product, map, record and other document, hereinafter collectively referred to as "Report" reproduced, prepared or caused to be prepared by Consultant pursuant to or in connection with this Agreement shall be the exclusive property of AHA. Consultant shall not copyright any Report required by this Agreement and shall execute appropriate documents to assign to AHA the copyright to Reports created pursuant to this Agreement. Any Report, information and data acquired or required by this Agreement shall become the property of AHA, and all publication rights are reserved to AHA.

All Reports prepared by Consultant may be used by AHA in execution or implementation of:

- (1) The original Project for which Consultant was hired;
- (2) Completion of the original Project by others;
- (3) Subsequent additions to the original project; and/or
- (4) Other AHA projects as appropriate.

Consultant shall, at such time and in such form as AHA may require, furnish reports concerning the status of services required under this Agreement.

All Reports required to be provided by this Agreement shall be printed on recycled paper. All Reports shall be copied on to both sides of the paper except for one original which shall be single sided.

No Report, information nor other data given to or prepared or assembled by Consultant pursuant to this Agreement shall be made available to any individual or organization by Consultant without prior approval by AHA

17. **RECORDS.**

Consultant shall maintain complete and accurate records with respect to sales, costs, expenses, receipts, and other such information required by AHA that relate to the performance of services under this Agreement. Consultant shall maintain adequate

records of services provided in sufficient detail to permit an evaluation of services. All such records shall be maintained in accordance with generally accepted accounting principles and shall be clearly identified and readily accessible. With reasonable notice, Consultant shall provide free access to the representatives of AHA or its designees to such books and records during normal business hours; and gives AHA the right to examine and audit same, and to make transcripts there from as necessary, and to allow inspection of all work, data, documents, proceedings and activities related to the performance of this Agreement. Such records, together with supporting documents, shall be kept separate from other documents and records and shall be maintained for a period of five (5) years after receipt of final payment.

18. **NOTICES.**

All notices, demands, requests or approvals to be given under this Agreement shall be given in writing and conclusively shall be deemed served when delivered personally or on the second business day after the deposit thereof in the United States mail, postage prepaid, registered or certified, addressed as hereinafter provided.

All notices, demands, requests or approvals from Consultant to AHA shall be addressed to AHA at:

Housing Authority of the City of Alameda  
701 Atlantic Avenue  
ALAMEDA CA 94501-2161  
Attention: Vanessa Cooper, Executive Director

All notices, demands, requests, or approvals from AHA to Consultant shall be addressed to Consultant at:

Aleshire & Wynder, LLP  
Adrian R. Guerra  
1 Park Plaza, Suite 1000  
Irvine, CA 92614  
aguerra@awattorneys.com  
(949) 223-1170

19. **NO SMOKING, DRINKING OR RADIO USE.**

Consultant agrees and acknowledges that smoking, drinking alcoholic beverages, and listening to radios is prohibited at any AHA site, including individual units, common areas, and every building and adjoining grounds. Consultant shall ensure that his/her employees and suppliers comply with these prohibitions.

20. **TERMINATION.**

AHA may, by written notice to Consultant, terminate this Agreement in whole or in part at any time, without cause, upon seven (7) days advance written notice. Such termination may be for AHA's convenience or because of Consultant's failure to perform its duties and obligations under this Agreement including, but not limited to, the failure of Consultant to timely perform services pursuant to this Agreement, including, but not limited to the Scope of Services attached as Exhibit A.

20.1 Discontinuance of Services. Upon termination, Consultant shall, unless otherwise directed by the notice, discontinue all services, and deliver to the AHA all data, estimates, graphs, summaries, reports, and other related materials as may have been prepared or accumulated by Consultant in performance of services, whether completed or

in progress.

20.2 Effect of Termination for Convenience. If the termination is to be for the convenience of AHA, then AHA shall compensate Consultant for services provided through the date of termination. Consultant shall provide documentation deemed adequate by AHA to show the services actually completed by Consultant prior to the date of termination, no later than 30 days after the date of termination. This Agreement shall terminate on the date of the written Notice of Termination delivered to Consultant.

20.3 Effect of Termination for Cause. In the event Consultant hereto fails or refuses to perform any of the provisions hereof at the time and in the manner required hereunder, Consultant shall be deemed in default in the performance of this Agreement. If such default is not cured within a period of two (2) days after receipt by Consultant from AHA of written notice of default, specifying the nature of such default and the steps necessary to cure such default, AHA may terminate the Agreement forthwith by giving to the Consultant written notice thereof. If the termination is due to the failure of Consultant to fulfill its obligations under this Agreement, Consultant shall be compensated for those services which have been completed in accordance with this Agreement. In such case, AHA may take over the work and prosecute the same to completion by contract or otherwise. Prior to discontinuance of services, AHA may arrange for a meeting with Consultant to determine what steps, if any, Consultant can take to adequately fulfill its requirements under this Agreement. In its sole discretion, AHA may propose an adjustment to the terms and conditions of the Agreement, including the contract price. Such contract adjustments, if accepted in writing by the parties, shall become binding on Consultant and shall be performed as part of this Agreement. Termination of this Agreement for cause may be considered by AHA in determining whether to enter into future agreements with Consultant.

20.4 Cumulative Remedies. The rights and remedies of the parties provided in this Paragraph are in addition to any other rights and remedies provided by law, equity or under this Agreement.

20.5 Removal and Replacement of Consultant Employee.  
If Consultant's staff member assigned to perform direct hire placement services for the AHA is: a) determined unsatisfactory by AHA, or b) terminates employment with Consultant while working at AHA, Consultant agrees to notify AHA in writing within four business hours for confirmation of the assignment of another qualified Consultant employee who will report to the job on the next business day as a replacement.

## 21. **FORCE MAJEURE.**

If either party is unable to comply with any provision of this Agreement due to causes beyond its reasonable control, and which could not have been reasonably anticipated, such as Acts of God, acts of war, civil disorders, or other similar acts, such party shall not be held liable for such failure to comply, provided the other party receives written notice of such force majeure event no later than fourteen (14) calendar days after commencement of such force majeure event.

## 22. **COMPLIANCES.**

Consultant shall comply with all state and federal laws, including, but not limited to state prevailing wage laws to the extent applicable, all City of Alameda ordinances, and all rules and regulations enacted or issued by AHA. In the event that the Consultant encounters a potential conflict between state, federal or local law, Consultant shall inform AHA and AHA shall direct Consultant on proper course of action.

**23. GOVERNING LAW: SEVERABILITY.**

This Agreement shall be interpreted under and enforced by the laws of the State of California excepting any choice of law rules which may direct the application of laws of another jurisdiction. The Agreement and obligations of the parties are subject to all valid laws, orders, rules, and regulations of the authorities having jurisdiction over this Agreement (or the successors of those authorities.) Any suits brought pursuant to this Agreement shall be filed with the Courts of the County of Alameda, the State of California, and the parties waive any provision of law providing for a change of venue to another location. In the event any provision in this Agreement is held by a court of competent jurisdiction to be invalid, void, or unenforceable, the remaining provisions will nevertheless continue in full force without being impaired or invalidated in any way.

**24. NONCONFORMING PAYMENTS.**

In the event Consultant receives payment under this Agreement which is later disallowed by AHA for nonconformance with the terms of the Agreement, AHA may offset the amount disallowed from any payment due to Consultant under this Agreement.

**25. NO PARTIAL DELIVERY OF SERVICES.**

Consultant shall not provide partial delivery or shipment of services or products unless specifically stated in the Agreement.

**26. LABOR STANDARDS.**

Consultant shall comply with all requirements of the Occupational Safety and Health Administration (OSHA) standards and codes as set forth by the U.S. Department of Labor and the State of California (Cal/OSHA).

**27. SOCIAL MEDIA/ADVERTISEMENT.**

Consultant shall not post, exhibit, display or allow to be posted, exhibited, or displayed any information, signs, advertising, show bills, lithographs, posters or cards of any kind pertaining to the services performed under this Agreement unless prior written approval has been secured from AHA to do otherwise. This prohibition includes, but is not limited to, posting any information as to this Agreement and Consultant's relationship with AHA on Facebook, Twitter, LinkedIn, Yelp, Instagram and any other social media.

**28. CONFIDENTIALITY.**

**28.1. Definition.** Consultant shall observe all Federal, State and AHA regulations applicable to the Services concerning confidentiality of records. Consultant shall not use for personal gain or make other improper use of privileged or confidential information which is acquired in connection with this Agreement. The term "privileged or confidential information" includes but is not limited to: any information or data obtained by Consultant relating to AHA clients and tenants and any opinions and conclusions based upon such information, unpublished or sensitive technological or scientific information; medical, personnel, or security records; anticipated material requirements or pricing/purchasing actions; AHA information or data which is not subject to public disclosure; AHA operational procedures; and knowledge of selection of contractors, subcontractors or suppliers in advance of official announcement, and any personally identifiable information protected under The Privacy Act of 1974(5 U.S.C. Section 552a), Section 6 of the Housing Act of 1937, The Freedom of Information Act (FOIA), 5 U.S.C. § 552, Section 208 of The E-Government Act, and HUD Notice PIH 2-15-06 issued on April 23, 2015.

28.2. **Nondisclosure and Nonuse Obligation.** Consultant agrees to perform all services hereunder in accord with this Agreement and agrees that all services shall be performed by qualified and experienced personnel who are not employed by the AHA nor have any contractual relationship with AHA. Consultant agrees that it will not use, disseminate, or in any way disclose any Confidential Information to any person, firm, or business, except that Consultant may use Confidential Information to the extent necessary to perform its obligations under this Agreement. Consultant agrees that it shall treat all Confidential Information with the same degree of care as the Consultant accords to its own Confidential Information, but in no case less than reasonable care. Consultant agrees that it shall disclose Confidential Information only to those of its employees who need to know such information, and the Consultant certifies that such employees have previously agreed, as a condition of employment, to be bound by terms and conditions applicable to Consultant under this Agreement. Consultant shall immediately give notice to AHA of any unauthorized use or disclosure of Confidential Information. For agreements involving information technology or access to agency data, the consultant shall be expected to use the same degree of care, but no less than a reasonable degree of care, to prevent the unauthorized use, dissemination, or publication of the agency's information, as it uses to protect its own, including standard anti-virus/malware deployment.

28.3. **Exclusions from Nondisclosure and Nonuse Obligations.** The obligations under 28.2 ("Nondisclosure and Nonuse Obligation") shall not apply to such portion that Consultant can document was i) in the public domain at the time such portion was disclosed or used, or ii) was disclosed in response to a valid court order.

28.4. **Ownership and Return of Confidential Information and Other Materials.** All Confidential Information shall remain the property of the AHA. At AHA's request and no later than five (5) business days after such request, Consultant shall promptly destroy or deliver to AHA, at AHA's option, i) all materials furnished to Consultant, ii) all tangible media of expression in Consultant's possession or control to the extent that such tangible media incorporate any of the Confidential Information, and iii) written certification of the Consultant's compliance with such obligations under this sentence.

29. **WAIVER.**

Any waiver by AHA of any breach of any one or more of the terms of this Agreement shall not be construed to be a waiver of any subsequent or other breach of the same or of any other term of this Agreement. Failure on the part of AHA to require exact, full, and complete compliance with any terms of this Agreement shall not be construed as in any manner changing the terms or preventing AHA from enforcement of the terms of this Agreement.

30. **CAPTIONS.**

The captions in this Agreement are for convenience only, are not a part of the Agreement and in no way affect, limit or amplify the terms or provisions of this Agreement

31. **ADMINISTRATION.**

The AHA Executive Director (or designee) shall administer this Agreement on behalf of AHA and may issue all consents, approvals, directives, and agreements on behalf of AHA called for by this Agreement, except as otherwise expressly provided for in this Agreement.

**32. GENERAL.**

32.1 The Consultant shall comply with all applicable Federal, State, and local laws and regulations. The Consultant will comply with all applicable AHA policies and procedures set forth in this Agreement. In the event that there is a conflict between the various laws or regulation that may apply, the Consultant shall comply with the more restrictive law or regulation.

32.2 Consultant represents and warrants that Consultant is registered to do business in the State of California with the California Secretary of State.

32.3 The parties to this Agreement acknowledge and agree that the provisions of this Agreement are for the sole benefit of AHA and Consultant, and not for the benefit, directly or indirectly, of any other person or entity, except as otherwise expressly provided herein.

32.4 Consultant acknowledges that AHA may enter into agreements with other consultants for services similar to the services that are the subject of this Agreement or may have its own employees perform services similar to the services contemplated by this Agreement.

32.5 Without limiting Consultant's hold harmless, indemnification and insurance obligations set forth herein, in the event any claim or action is brought against AHA relating to Consultant's performance or services rendered under this Agreement, Consultant shall render any reasonable assistance and cooperation which AHA shall require at the relevant contract rates.

32.6 As used in this Agreement, the term Consultant also includes Consultant's owners, officers, employees, representatives, and agents.

32.7 Limitation of Liability. Circumstances may arise where, because of a default on Consultant's part or other liability, the AHA is entitled to recover damages from Consultant. Regardless of the basis on which the AHA is entitled to claim damages from Consultant (including breach, negligence, misrepresentation, or other contract or tort claim), Consultant's liability, if any, will (in the aggregate for all claims, causes of action or damages) be limited to four times the contract amount of this Agreement.

32.8 Under no circumstances is either party liable to the other for special, incidental or indirect damages or for any consequential damages (including lost profits, business, revenue, goodwill, or anticipated savings), even if informed of the possibility.

32.9 EXCEPT AS SET FORTH IN EXHIBIT A, CONSULTANT MAKES NO EXPRESS OR IMPLIED WARRANTIES REGARDING THE SERVICES, INCLUDING, BUT NOT LIMITED TO, ANY WARRANTY OF QUALITY, PERFORMANCE, MERCHANTABILITY OR FITNESS FOR ANY PURPOSE.

**33. ADDITIONAL FEDERAL REQUIREMENTS.**

Whereas the work or services herein may be subject to applicable Federal, State, and local laws and regulations, including but not limited to the regulations pertaining to the

Community Development Block Grant program (24 CFR Part 570) and the Uniform Administrative Requirements, Cost Principles and Audit Requirements for Federal Awards (2 CFR Part 200). Notwithstanding anything to the contrary in this Agreement or any exhibit hereto, AHA acknowledges that this Agreement is not a contract for construction or repair services; Consultant, contractors, its sub-contractors, consultants, and sub-consultants shall comply with, and are subject to, the following requirements only to the extent they are applicable, and only to the extent as such federal laws, rules, regulations and Executive Orders may have been modified, amended, supplanted or rescinded:

33.1 Equal Employment Opportunity - Compliance with Executive Order 11246 of September 24, 1965, entitled "Equal Employment Opportunity", as amended by Executive Order 11375 of October 13, 1967, and as supplemented in Department of Labor regulations (41 CFR chapter 60): The Consultant shall not discriminate against any employee or applicant for employment because of race, color, religion, sex, or national origin. Consultant shall ensure that all qualified applicants shall receive consideration for employment without regard to race, color, religion, sex or national origin. The Consultant shall take affirmative action to ensure that applicants are employed and the employees are treated during employment, without regard to their race color, religion, sex, or national origin. Such actions shall include, but are not limited to, the following: employment, up-grading, demotion, or transfer; recruitment or recruitment advertising; rates of pay or other forms of compensation; and selection for training, including apprenticeship. The Consultant shall post in a conspicuous place, available to employees and applicants for employment, notices to be provided by AHA setting forth the provisions of this non-discriminating clause.

33.2 Copeland "Anti-Kickback" Act (18 U.S.C. 874 and 40 U.S.C. 276c): All contracts and subgrants in excess of \$2,000 for construction or repair awarded by recipients and subrecipients shall include a provision for compliance with the Copeland "Anti-Kickback" Act (18 U.S.C. 874), as supplemented by Department of Labor regulations (29 CFR part 3, "Contractors and Subcontractors on Public Building or Public Work Financed in Whole or in Part by Loans or Grants from the United States"). The Act provides that each contractor or subrecipient shall be prohibited from inducing, by any means, any person employed in the construction, completion, or repair of public work, to give up any part of the compensation to which he is otherwise entitled. The recipient shall report all suspected or reported violations to the U.S. Department of Housing and Urban Development, (HUD).

33.3 Davis-Bacon Act, as amended (40 U.S.C. 276a to a-7): When required by Federal program legislation, all construction contracts awarded by the recipients and subrecipients of more than \$2000 shall include a provision for compliance with the Davis-Bacon Act (40 U.S.C. 276a to a-7) and as supplemented by Department of Labor regulations (29 CFR part 5, "Labor Standards Provisions Applicable to Contracts Governing Federally Financed and Assisted Construction"). Under this Davis-Bacon Act, contractors shall be required to pay wages to laborers and mechanics at a rate not less than the minimum wages specified in a wage determination made by the Secretary of Labor. In addition, contractors shall be required to pay wages not less than once a week. The recipient shall place a copy of the current prevailing wage determination issued by the Department of Labor in each solicitation and the award of a contract shall be conditioned upon the acceptance of the wage determination. The recipient shall report all suspected or reported violations to HUD.

33.4 Contract Work Hours and Safety Standards Act (40 U.S.C. 327 through 333): Where applicable, all contracts awarded by recipients in excess of \$2000 for construction contracts and in excess of \$2500 for other contracts that involve the employment of mechanics or laborers shall include a provision for compliance with

Sections 102 and 107 of the Contract Work Hours and Safety Standards Act (40 U.S.C. 327-333), as supplemented by Department of Labor regulations (29 CFR part 5). Under Section 102 of the Contract Work Hours and Safety Standards Act, each contractor shall be required to compute the wages of every mechanic and laborer on the basis of a standard workweek of 40 hours. Work in excess of the standard workweek is permissible provided that the worker is compensated at a rate of not less than 1 1/2 times the basic rate of pay for all hours worked in excess of 40 hours in the workweek. Section 107 of the Contract Work Hours and Safety Standards Act is applicable to construction work and provides that no laborer or mechanic shall be required to work in surroundings or under working conditions which are unsanitary, hazardous, or dangerous. These requirements do not apply to the purchases of supplies or materials or articles ordinarily available on the open market, or contracts for transportation or transmission of intelligence.

33.5 Rights to Inventions Made Under a Contract or Agreement: Contracts or agreements for the performance of experimental, developmental, or research work shall provide for the rights of the Federal Government and the recipient in any resulting invention in accordance with 37 CFR part 401, "Rights to Inventions Made by Nonprofit Organizations and Small Business Firms Under Government Grants, Contracts and Cooperative Agreements," and any implementing regulations issued by HUD.

33.6 Rights to Data and Copyrights: Consultants and contractors shall comply with all applicable provisions pertaining to the use of data and copyrights pursuant to 48 CFR Part 27.4, Federal Acquisition Regulations (FAR).

33.7 Clean Air Act (42 U.S.C. 7401 et seq.) and the Federal Water Pollution Control Act (33 U.S.C. 1251 et seq.), as amended: Contracts and subgrants of amounts in excess of \$100,000 shall contain a provision that requires the recipient to agree to comply with all applicable standards, orders or regulations issued pursuant to the Clean Air Act (42 U.S.C. 7401 et seq.) and the Federal Water Pollution Control Act as amended (33 U.S.C. 1251 et seq.). Violations shall be reported to HUD and the Regional Office of the Environmental Protection Agency (EPA).

33.8 Byrd Anti-Lobbying Amendment (31 U.S.C. 1352): Contractors who apply or bid for an award of \$100,000 or more shall file the required certification. Each tier certifies to the tier above that it will not and has not used Federal appropriated funds to pay any person or organization for influencing or attempting to influence an officer or employee of any agency, a member of Congress, officer or employee of Congress, or an employee of a member of Congress in connection with obtaining any Federal contract, grant or any other award covered by 31 U.S.C. 1352. Each tier shall also disclose any lobbying with non-Federal funds that takes place in connection with obtaining any Federal award. Such disclosures are forwarded from tier to tier up to the recipient.

33.9 Debarment and Suspension (Executive Orders (E.O.s) 12549 and 12689): No contract shall be made to parties listed on the General Services Administration's List of Parties Excluded from Federal Procurement or Non-procurement Programs in accordance with E.O.s 12549 and 12689, "Debarment and Suspension," as set forth at 24 CFR part 33. This list contains the names of parties debarred, suspended, or otherwise excluded by agencies, and contractors declared ineligible under statutory or regulatory authority other than E.O. 12549. Contractors with awards that exceed the small purchase threshold shall provide the required certification regarding its exclusion status and that of its principal employees.

33.10 Drug-Free Workplace Requirements: The Drug-Free Workplace Act of 1988 (42 U.S.C. 701) requires grantees (including individuals) of federal agencies, as a prior condition of being awarded a grant, to certify that they will provide drug-free workplaces. Each potential recipient shall certify that it will comply with drug-free workplace requirements in accordance with the Drug-Free Workplace Act and with HUD's rules at 24 CFR part 24, subpart F.

33.11 Access to Records and Records Retention: Consultant, and any sub.; consultants or sub-contractors, shall allow all duly authorized Federal, State, and/or AHA officials or authorized representatives access to the work area, as well as all books, documents, materials, papers, and records of Consultant, and any sub-consultants or sub-contractors, that are directly pertinent to a specific program for the purpose of making audits, examinations, excerpts, and transcriptions. The Consultant, and any sub-consultants or sub-contractors, further agree to maintain and keep such books, documents, materials, papers, and records, on a current basis, recording all transactions pertaining to this Agreement in a form in accordance with generally acceptable accounting principles. All such books and records shall be retained for such periods of time as required by law, provided, however, notwithstanding any shorter periods of retention, all books, records, and supporting detail shall be retained for a period of at least four (4) years after the expiration of the term of this Agreement.

33.12 Federal Employee Benefit Clause: No member of or delegate to the congress of the United States, and no resident commissioner shall be admitted to any share or part of this Agreement or to any benefit to arise from the same.

33.13 Energy Efficiency: Mandatory standards and policies relating to energy efficiency which are contained in the State energy conservation plan issued in compliance with the Energy Policy and Conservation Act (Pub. L. 94A 163, 89 Stat. 871).

#### 34. **BUILD AMERICA, BUY AMERICA COMPLIANCE**

34.1 Applicable law: Pursuant to the Build America, Buy America Act (BABA), enacted as part of the Infrastructure Investment and Jobs Act (IIJA). Pub. L. 117-58, 41 U.S.C. § 8301 note, the Federal Financial Assistance used to fund this infrastructure project is required to apply a domestic content procurement preference (the "Buy America Preference" or "BAP") for all construction, alteration, maintenance, or repair of infrastructure, including buildings and real property, unless application of the BAP has been waived by HUD. Build America, Buy America Act is defined in 2 CFR 184.3 and means division G, title IX, subtitle A, parts I–II, sections 70901 through 70927 of the Infrastructure Investment and Jobs Act (Pub. L. No. 117-58) Additional details on fulfilling the BABA requirements can be found at [https://www.hud.gov/program\\_offices/general\\_counsel/build\\_america\\_buy\\_america](https://www.hud.gov/program_offices/general_counsel/build_america_buy_america).

#### 34.2 BABA Compliant/Non-BABA Compliant Proposal Submission Requirements .

Consultant has complied with, and shall continue to comply with, the following requirements in connection with the procurement relating to this Contract (for purposes of this section 34, the term "bidder" means the Consultant):

Consultant submitted both BABA compliant and non-BABA compliant proposals:

The AHA is requiring bidders responding to this solicitation to provide alternative responses depending on whether the bidder responding to the solicitation is successfully able to find the necessary BABA compliant products:

- i. Bidders that are successful in finding needed BABA compliant products shall respond to this solicitation with two responses: one that is BABA compliant and one that is not;
- ii. Bidders that are not successful (or only partially successful) shall respond by submitting a complete response that is not BABA compliant as well as a response that indicates that the bidder was unable to find the necessary BABA compliant products, and submit documentation compliant with the following minimum due diligence search requirements in lieu of a BABA compliant response to the solicitation:
  - (1) For micro purchases as defined by 2 CFR part 200 with procedures described in 2 CFR 200.320):
    - a. Bidder must search for the required product using one of the top five most used Internet search engines or the website of one of the top five home improvement retailers while using one of the following search terms: “made in America” or “made in the USA;”
    - b. If none of the top 10 results of the search indicate that the product is made in America, the bidder is not required to search further;
    - c. If one or more of the search results indicates the product is made in America, the bidder must take the additional step of contacting the maker(s) of the product by email or by phone to confirm that the product meets the BABA requirements for the product. If the product maker either confirms that the product is not BABA compliant or that BABA compliance is uncertain, or if the product maker fails to respond to the inquiry within two business days, the bidder is not required to search further.
  - (2) For small purchases as described in procedures in regulations at 2 CFR 200.320(a)(2):
    - a. Bidder must search for the required product using at least two search attempts either using one of the top five most used Internet search engines or the website of one of the top five home improvement retailers while using one of the following search terms: “made in America” or “made in the USA;”
    - b. If none of the top 20 results of both searches indicate that the product is made in America, bidder is not required to search further;
    - c. If one or more of the search results indicates the product is made in America, bidder is to contact the maker(s) of the product by email or by phone to confirm that the product meets the BABA requirements for the product. If the product makers either confirm that the maker’s product is not BABA compliant or that BABA compliance is uncertain, or if the product maker fails to respond to the inquiry within two business days, the bidder is not required to search further.
  - (3) For purchases that meet or exceed the simplified acquisition threshold amount as defined 2 CFR 200.1:1:
    - a. The bidder must search for the required product using at least three search attempts either using one of the top five most used Internet search engines or the website of one of the top five home improvement retailers while using one of the following search terms: “made in America” or “made in the USA;”
    - b. If none of the top 30 results of both searches indicate that the product is made in America, the bidder is not required to search further;
    - c. If one or more of the search results indicates the product is made in America, the bidder is to contact as many makers as the search results indicate are made in America, up to a maximum of five products, by email or by phone to confirm that the product meets the BABA requirements for the product. If the contacted product makers either confirm that the maker’s product is not BABA compliant or that BABA compliance is uncertain, or if the product maker fails to respond to the inquiry within five business days, the bidder is not required to search further.
  - (4) Bidder shall document compliance with the minimum search requirements discussed above including:
    - a. Copies of searches used (e.g. PDF/JPEG copies of web pages showing search terms and results);
    - b. Copies of email correspondence with product makers;
    - c. Records of phone contacts with product makers, including;

- i. Dates and times of phone communications;
  - ii. phone numbers used;
  - iii. Whether the phone communication was successful in making it possible to reach a staff person for the product maker able to respond to questions about BABA compliance, or whether the attempt at communication was unsuccessful (e.g., left a message, phone line was busy, or phone line was disconnected);
  - iv. If the phone communication resulted in reaching someone, the name of the person contacted; and
  - v. Notes describing the substance of the conversation (e.g., manufactured product is assembled in U.S., but the manufacturer is uncertain whether 55% of the value of the materials/components are sourced in the U.S.).
35. **HUD Requirements.** Consultant agrees to comply with all relevant HUD requirements, including those set forth in the General Conditions for Non-Construction Contracts, form HUD-5370-C (11/30/2023), attached hereto as Exhibit "D" and incorporated as if fully set forth herein. In the event of a conflict between the provisions in the body of this Contract and Exhibit "D", the provisions set forth in Exhibit "D" shall prevail.
36. **NONLIABILITY OF AHA OFFICIALS AND EMPLOYEES.**  
No member, official employee or consultant of AHA shall be personally liable to the Consultant, or any successor in interest, in the event of any default or breach by AHA or for any amount which may become due to the Consultant or to its successor, or on any obligation under the terms of this Agreement.
37. **ENTIRE AGREEMENT.**  
This Agreement, including any attachments or exhibits, constitutes the entire Agreement of the parties with respect to its subject matter and supersedes all prior and contemporaneous representations, proposals, discussions and communications, whether oral or in writing. This Agreement may be changed or modified only by a written amendment signed by authorized representatives of both parties.
38. **AUTHORITY TO SIGN.**  
Consultant hereby represents that the persons executing this Agreement on behalf of Consultant have full authority to do so and to bind Consultant to perform pursuant to the terms and conditions of this Agreement.
39. **EXHIBITS.** The following exhibits are attached hereto and incorporated herein by this reference:
- i. Exhibit A - Scope of Services
  - ii. Exhibit B - Fee Schedule
  - iii. Exhibit C - Insurance Requirements for Consultants
  - iv. Exhibit D - Form HUD-5370-C

[SIGNATURES ON FOLLOWING PAGE]

IN WITNESS WHEREOF, the parties have caused the Agreement to be executed on the day and year first above written.

**"CONSULTANT"**

**ALESHIRE & WYNDER, LLP**

By: \_\_\_\_\_

Name: Adrian R. Guerra

Its: Partner

**"AHA"**

**HOUSING AUTHORITY OF THE CITY OF ALAMEDA**, a public body, corporate and politic

By: \_\_\_\_\_  
Vanessa Cooper, Executive Director

By: \_\_\_\_\_

Carly Grob, Board of Commissioners Chair

**EXHIBIT A**  
**SCOPE OF SERVICES**

**AHA Standards and Requirements for General Counsel**

- **Assignments of work:** Counsel is managed through the Executive Director, unless otherwise delegated. Work is generally assigned on an “as needed” basis apart from routine tasks and meetings. Counsel will perform only work which is authorized by AHA.
- **Billing:** Timely, accurate billing is expected, separated by case/project. Billing should include a statement of any past due amounts. Counsel must be paid through EFT or ACH.
- **Board Meetings:** Counsel shall attend meetings, including the AHA Board of Commissioners and its legal affiliates’ board meetings, as requested remotely or in person, as determined by the Authority.
- **Changes in the law:** Counsel will proactively alert the Authority to changes in the law or regulation that may impact its business.
- **Conflict of interest:** Counsel will not undertake any representation or other relationship that places it in an actual or potential conflict of interest position with any other entity. Counsel shall submit a conflict of interest statement annually in January using the follow link <https://form.alamedahsg.org/Forms/A4Gpo>. Counsel shall also inform AHA of any new conflicts of interest as soon as they occur. Counsel may be removed from specific projects where there is no waiver or letter for joint counsel. Counsel or firm shall be responsible for timely disclosure of all current and known future projects which may cause conflict of interest during the contract. Any consent and/or waiver to the conflict must be obtained in writing and is generally only given with Board approval. Counsel or firm will provide conflict of interest waivers, letters of joint representation etc. for the Board to review for all conflicts within 60 days of the award or amendment and when new conflicts arise.
- **Deadlines:** AHA is a fast-paced and rapidly-growing agency with a wide range of legal needs, some of which are needed at short notice. Work products shall be provided within 2 business days unless a different deadline is agreed between the firm and the Executive Director or designee. Routine communications via phone and/or emails shall be responded to within 24 hours, except for weekends and holidays. Counsel will meet deadlines as agreed and provide routine updates.
- **Fair Housing:** Counsel is required to promote fair housing and comply with the Fair Housing Act and fair housing laws and regulations.
- **Form 700:** General Counsel (and other counsel as necessary) shall submit a California Form 700 (Statement of Economic Interest) within 30 days of the contract being signed and annually thereafter in accordance with state timelines. This shall be submitted through AHA’s online system.
- **Insurance:**-See also insurance requirements via Exhibit E- Attachment C- Counsel shall submit proof of insurance upon contract execution and annually in January and must include AHA and its affiliated entities as additionally insured. Counsel must also have Cyber Liability insurance.
- **Records:** All documents and products created by the General Counsel and any subcontractors exclusively for AHA , shall become the exclusive property of AHA. Counsel shall be required to retain all pertinent records in accordance with AHA’s Records Retention Schedule and for a minimum of the duration of the contract, plus additional years, as indicated by AHA’s Record Retention Schedule.-Counsel has been provided with the Record Retention Schedule- AHA, HUD, and the Comptroller General of the United States shall at all times have access to any books, documents, papers, and records of the Counsel which are directly pertinent to the specific contract for the purpose of audit, examination, or for excerpts or transcripts.
- **Replacement Counsel:** Firm shall provide replacement counsel to meet expectations if assigned counsel is unavailable.
- **Response to Auditors:** Counsel will be required to respond timely to requests from the Authority’s outside auditors annually.
- **Staff meetings/reports:** Counsel may be required to attend a weekly or monthly meeting and/or provide a weekly or monthly written report as determined by the Authority.
- **Subcontractors:** Counsel will hire only additional counsel (sub-contractors) with the express written authorization of AHA. All subcontractors are subject to the approval of AHA.

- **Use of AHA’s case management system of record:** Counsel is required to utilize and upload legal case documents timely to Authority’s assigned software, currently MyCase. A license and training will be provided by AHA.
- **Work standards:** All work to be performed by AHA’s Counsel is to be performed in accordance with professional standards, HUD regulations, requirements and criteria and local codes, regulations, ordinances, and statutes. All documents produced under contract to AHA must be submitted in a format to which both parties agree.
- **Evaluation:** General Counsel may be evaluated by the Board and Executive Director periodically as needed and especially before any contract renewal or extension. The Evaluation will occur in closed session to the extent permissible by law.

### **General Counsel**

- Confer with and advising the officers, employees, and members of the Board of Commissioners of the Authority on legal matters and issues when requested.
- Provide regular and timely updates to key legislation, policy or regulation changes that impact the activities of AHA and its affiliated entities, including but not limited to State and Federal law changes for government agencies, public officials-and housing and HUD regulations.
- Research, interpret laws, proposed legislation, case law, and other statutory authorities pertaining to Federal, State and local government on the following topical areas: housing, housing programs, affordable housing finance, real estate development, procurement, and contracts.
- Research, interpret, and provide legal guidance on administrative and governance matters, including but not limited to, matters under the Freedom of Information Act and-California Public Records Act, the Ralph M. Brown Act, Political Reform Act, and similar laws. Prepare articles of incorporation, partnership agreements, bylaws, resolutions, and similar documents for Authority and its affiliates as needed.
- Provide routine legal guidance and consultation on matters relevant to Authority ‘s functional areas such as Housing Programs, Real Estate Development, Asset Management, Human Resources, Finance, Administrative Services, and Information Technology, as needed.
- Attend weekly legal “General Counsel (GC) office hours” meeting with the Executive Director and staff at a fixed time and provide guidance on issues discussed.-An advance agenda is provided. Provide timely updates to GC meeting agenda items and issues discussed in the GC meeting.
- Respond to or assist staff in responding to legal notices. Represent the Authority before courts of law and administrative agencies, if requested.
- When litigation commences and General Counsel is appointed as lead counsel, lead preparation of a defense, update the Authority as necessary, act as lead counsel including but not limited to court appearance, pretrial preparation, filing of motions, discovery and negotiations, provide legal research, legal analysis, factual information, investigations. (Note: most litigation is contracted with the insurer’s chosen legal provider under a separate contract with the insurance provider).
- Prepare legal opinions, position papers, oral or written reports on any matters outlined above and advise the Board of Commissioners and staff, accordingly. Recommend the retention of specialized legal counsel, when appropriate
- Review all hearing decisions prior to issuance.
- Review of Public Records Act requests, county records, and legal documents, papers, contracts, agreements, upon request and such other legal drafting may be required.
- Provide annual in-person training of staff and Board on Brown Act and Public Records Act.
- Provide, with Staff input, a quarterly written legal update to the Board.
- Conduct conflict of interest reviews in relations to Board members, Staff and Vendors.

#### General Counsel role relating to Public Meetings and Board business.

- In-person attendance and guidance during any and all Housing Authority Board of Commissioners meetings (regular or special) and all affiliate Board meetings.
- Review all agendas before publication,as to form and consistency between captions and memos. Review the content of memos that relate to compliance with Board, and\_ HUD, matters and on-any agenda items where General Counsel are also lead counsel or a review is requested. Provide comments in accordance with the Authority’s Board preparation timeline and in the Authority’s designated software system.

- Be available for questions and consultation from 12 noon – 2pm on the day of packet publication and from 12 noon -2pm on the day of the Board meeting.
- The attorney attending the meeting will ensure they have reviewed the Board packet prior to the meeting.
- Attend a monthly pre-board meeting with Board Chair and Executive Director (remote).
- Attend the Board of Commissioner and all affiliate Board meetings in person.-Respond to questions and interject in the meeting, if needed, and address any issues of legal, bylaw or Robert's rules compliance.
- Guide closed session discussions during meetings (except Executive Director's evaluation). to ensure Brown Act compliance.
- Review draft minutes and approve final as to form only. Ensure form of minutes and agendas comply with the Bylaws.

**EXHIBITS**  
**TEE SCHEDULE**

Consultant Name Aleshire & Wynder, LLP	Position	Hourly Fee YEAR 1	Hourly Fee YEAR 2	Hourly Fee YEAR 3	Hourly Fee YEAR 4	Hourly Fee YEAR 5
<b>General Counsel Services</b>	Partners	\$340	\$350	\$360	\$370	\$380
	Senior Associates	\$320	\$330	\$340	\$350	\$360
	Associates	\$300	\$310	\$320	\$330	\$340

**Travel time for attorneys will be billed in accordance with the following structure:**

**Attorney Time for Travel shall be implemented as follows:**

- Travel between Attorney offices (Irvine, Los Angeles, Fresno, Bay Area, or San Diego) and the Agency’s office will be limited to a maximum of 2.5 hours each way, billed at a rate of \$250 per hour.
- Travel within Alameda County for attendance at in-person meetings, court appearances, depositions, administrative hearings, or other meetings and appearances will be billed based on actual travel time each way at a rate of \$250 per hour.
- Travel between Attorney offices (Irvine, Los Angeles, Fresno, Bay Area, or San Diego) to other locations on behalf of the Agency, such as Sacramento or Washington, D.C., will be billed based on actual travel time each way at a rate of \$250 per hour.
- Travel expenses, including mileage or other transportation costs, will be billed in accordance with the Housing Authority of the City of Alameda’s Travel Procedures (Attachment F). Mileage reimbursement will be calculated using the current IRS mileage rate, when applicable.

**EXHIBIT C**  
**INSURANCE REQUIREMENTS FOR CONSULTANTS**

Consultant shall procure and maintain for the duration of the Agreement, insurance against claims for injuries to persons or damages to property which may arise from or in connection with the performance of the work hereunder and the results of that work by the Consultant, its agents, representatives, employees, or subcontractors.

**MINIMUM SCOPE AND LIMIT OF INSURANCE**

Coverage shall be at least as broad as:

- **IF APPLICABLE: Tenant Discrimination:** For consultants interacting with the public or with tenants, coverage must include coverage for discrimination, harassment, and fair housing claims under the California Civil Rights Department (CRD) and HUD in Consultant's Commercial General Liability policy, or Professional Liability/Errors and Omissions (E&O) policy, or in a separately maintained Tenant Discrimination insurance policy.
- **Commercial General Liability (CGL):** Insurance Services Office Form CG 00 01 covering CGL on an "occurrence" basis, including products and completed operations, property damage, bodily injury, and personal and advertising injury with limits no less than \$2,000,000 per occurrence. If a general aggregate limit applies, either the general aggregate limit shall apply separately to this project/location (ISO CG 25 03 or 25 04) or the general aggregate limit shall be twice the required occurrence limit.
- **Automobile Liability:** ISO Form Number CA 00 01 coverage any auto (Code 1), or if Consultant has no owned autos, hired (Code 8) and non-owned autos (code 9) with limit no less than \$1,000,000 for bodily injury and property damage. This requirement does not apply if no motor vehicles are used in providing services under the Agreement.
- **Workers' Compensation** as required by the State of California, with Statutory Limits and Employers' Liability Insurance with limit of no less than \$1,000,000 per accident for bodily injury or disease. This requirement does not apply to sole proprietors.
- **IF APPLICABLE: Sexual Abuse or Molestation (SAM) Liability:** Consultants that may interact with children or vulnerable adults must retain SAM insurance. If the CGL policy referenced above is not endorsed to include affirmative coverage for sexual abuse or molestation, Consultant shall obtain and maintain a policy covering Sexual Abuse and Molestation with a limit no less than \$1,000,000 per occurrence or claim.

- **IF APPLICABLE: Professional Liability (Errors and Omissions):** Insurance appropriate to the Consultant's profession, with limit no less than \$2,000,000 per occurrence or claim, \$2,000,000 in the aggregate. If coverage is provided on a claims-made basis, the retroactive date must be shown and must be before the date of the contract or the beginning of the contract work. insurance must be maintained, and evidence of coverage must be provided for at least five (5) years after completion of the contract of work. If coverage is cancelled or non-renewed and not replaced with another claims-made policy form with a retroactive date prior to the contract effective date, the Consultant must purchase "extended reporting" coverage for a minimum of five (5) years after the completion of work.
- **IF APPLICABLE: Cyber Liability Insurance:** Coverage is required if the Consultant is accessing, collecting, storing, or transferring Personally Identifiable Information (PII), Personal Health Information (PHI), Payment Card Information (PCI), or medical information on staff, tenants, applicants etc.

  - Coverage shall be sufficiently broad to respond to the duties and obligations as is undertaken by Vendor in this agreement and shall include, but not be limited to, claims involving security breach, system failure, data recovery, business interruption, cyber extortion, social engineering, infringement of intellectual property, including but not limited to infringement of copyright, trademark, trade dress, invasion of privacy violations, information theft, damage to or destruction of electronic information, release of private information, and alteration of electronic information.
  - The policy shall provide coverage for breach response costs, regulatory fines, and penalties as well as credit monitoring expenses with limits not less than \$2,000,000 per occurrence or claim, \$2,000,000 aggregate.
- **IF APPLICABLE: Technology Professional Liability:** Coverage is required if the vendor/consultant is providing software or a technology service (data storage, website design, etc.).

  - Coverage shall be sufficiently broad to respond to the duties and obligations as is undertaken by Consultant in this agreement and shall include, but not be limited to, claims involving media liability and infringement of intellectual property, including but not limited to infringement of copyright, trademark, trade dress, security and privacy liability that include invasion of privacy violations, information theft, damage to or destruction of electronic information, release of private information, alteration of electronic. information, extortion and network security.
  - The policy shall provide coverage for breach response costs as well as regulatory fines and penalties as well as credit monitoring expenses with limits

sufficient to respond to these obligations. Limits must be no less than \$2,000,000 per occurrence or claim, \$4,000,000 in the aggregate.

- If coverage is provided on a claims-made basis, the retroactive date must be shown and must be before the date of the Agreement or the beginning of the contract work; insurance must be maintained, and evidence of coverage must be provided for at least five (5) years after completion of the Agreement of work. If coverage is cancelled or non-renewed and not replaced with another claims made policy form with a retroactive date prior to the Agreement effective date, the Consultant must purchase "extended reporting" coverage for a minimum of five (5) years after completion of work.
- The Policy shall include or be endorsed to include property damage liability coverage for damage to, alteration of, loss of, or destruction of the electronic data and/or information "property" of the AHA in the care, custody, or control of the Consultant. If not covered under the Consultant's Professional Liability policy, such property coverage of the AHA may be endorsed onto the Consultant's Cyber Liability Policy as follows:
  - Cyber Liability coverage in an amount sufficient to cover the full replacement value of damage to, alteration of, loss of, destruction of electronic data and/or information "property" of the AHA that will be in the Care, custody, or control of Consultant.

If the consultant maintains broader coverage and/or higher limits than the minimums shown above, AHA requires and shall be entitled to the broader coverage and/or the higher limits maintained by the consultant. The insurance limits required by AHA are not represented as being sufficient to protect Consultant. Consultant is advised to consult Consultant's insurance broker to determine adequate coverage for Consultant.

#### **OTHER INSURANCE REQUIREMENTS:**

The insurance policies are to contain, or be endorsed to contain, the following provisions:

- **Additional Insured Status:**

- The Housing Authority of the City of Alameda and its legal affiliates, Alameda Affordable Housing Corporation and Island City Development and its Subsidiaries and legal affiliates, and their departments, their respective directors, officers, Boards of Commissioners, employees, designated volunteers, elected or appointed officials, (Additional Insureds), are to be covered as additional insured on the CGL policy and, if applicable, the Cyber Liability policy with respect to liability arising out of work or operations performed by or on behalf of the Consultant including materials, parts, or equipment furnished in connection with such work or operations.

- General liability coverage can be provided in the form of an endorsement to the Consultant's insurance at least as broad as ISO Form CG 20 10 11 85. If CG 20 10 11 85 is not available, endorsement must be at least as broad as the addition of both CG 20 10 and CG 20 37; or CG 20 38 and CG 20 40.
- **Primary Coverage:**
  - For any claims related to this contract, the Consultant's insurance coverage shall be primary and non-contributory with coverage at least as broad as ISO CG 20 01 04 13 as respects Additional Insureds.
  - Any insurance or self-insurance maintained by Additional Insureds shall be excess of the Consultant's insurance and shall not contribute to it.
- **Waiver of Subrogation:**
  - Consultant hereby grants to AHA a waiver of any right to subrogation which any insurer of said Consultant may acquire against AHA by virtue of the payment of any loss under such insurance. Consultant agrees to obtain any endorsement that may be necessary to affect this waiver of subrogation, but this provision applies regardless of whether AHA has received a waiver of subrogation endorsement from the Insurer.
- **Failure to Secure:**
  - If Consultant, at any time during the term hereof, should fail to secure or maintain the foregoing insurance, AHA shall be permitted to immediately terminate this Agreement.
- **Notice of Cancellation:** Each insurance policy required above shall provide that coverage shall not be canceled, except with 30 days' notice to AHA.
- **Acceptability of Insurers:** Insurance is to be placed with insurers with a current A.M. Best's rating of no less than A: VII, unless otherwise acceptable to AHA
- **Verification of Coverage:**
  - Consultant shall furnish AHA with original certificates and amendatory endorsements or copies of the applicable policy language effecting coverage required by this clause, and a copy of the Declarations and Endorsement page of the CGL policy listing all policy endorsements before work begins.
  - Consultant shall furnish AHA with a complete copy of any Excess/Umbrella policies, with all endorsements, maintained by Consultant before work begins.
  - Failure to obtain the required documents prior to the work beginning shall not waive the Consultant's obligation to provide them.

- AHA reserves the right to require complete, certified copies of all required insurance policies, including endorsements required by these specifications, at any time.
- **Subcontractors:** Consultant shall pass down the insurance obligations contained herein to all tiers of subcontractors working under the contract.
- **Notification of claims:** The Proposer agrees to notify AHA in writing of any claim by a third party or any incident or event that may give rise to a claim arising from the performance of the contract as soon as practicable, but no later than three (3) business days after their first knowledge of such claim or event.
- **Special Risk or Circumstance:** AHA reserves the right to modify these requirements, including limits, based on the nature of the risk, prior experience, insurer, coverage, or other special circumstance.

**EXHIBIT D**  
**FORM HUD-5370-C1**  
**GENERAL CONDITIONS FOR NON-CONSTRUCTION**  
**CONTRACTS**

<https://www.hud.gov/sites/dfiles/OCHCO/documents/5370C1.pdf>



# ISLAND CITY DEVELOPMENT

Fax (510) 522-7848 | TTY/TRS 711

ITEM 6.A

To: Board of Directors  
Island City Development

From: Jocelyn Layte, Associate Project Manager

Date: May 20, 2026

Re: Authorize the President to Negotiate and Execute a First Amendment to the Consultant Services Agreement between Mabuhay and Lakehurst LP (Linnet Corner) and J.H. Fitzmaurice Increasing the Contract Amount by \$100,000 for a New Maximum Contract Amount Not to Exceed \$179,626, with an Existing Term of September 19, 2026, and Approved Option to Extend the Contract for One Six-Month Term to March 31, 2027.

## **BACKGROUND**

Linnet Corner is located at 2000 Lakehurst Circle, Alameda, CA 94501. The project is the new construction of a single, four (4) story residential building, with 64 units. J.H. Fitzmaurice, Inc. (JHF) initiated construction on March 4, 2024, and received a Certificate of Occupancy (COO) on August 25, 2025. The project has been fully leased as of February 28, 2026. JHF has continued to respond to warranty items and also to implement small additional changes requested by ICD to assist in smoother operations of the building.

## **DISCUSSION**

In October 2025, upgrades were identified for the building which require a contractor to complete the work. Mabuhay and Lakehurst LP have requested the work be done under the General Contractor and subcontractors who originally worked on the project during construction to preserve warranty rights.

In December 2025, the Board of Directors approved the contract for work between Mabuhay and Lakehurst LP and J.H. Fitzmaurice, which terminated as of February 28, 2026. A new contract with a term date of September 19, 2026, and an option to extend six months to March 2027. The proposed contract amendment will cover the costs of the remaining services needed for the property to receive the upgrades identified in the original contract and provide contingency for any final upgrades that may be identified prior to contract close out. Prior to this contract amendment, contract work on the water down spout reroutes, landscaping upgrades, and acoustical upgrades to ceiling tiles, and maintenance room camera installation were completed while ordering and installation began on noise attenuation upgrades and acoustic panels.

March 2026 contract total	\$ 79,626
Work completed as of May 1, 2026	\$ 61,960



Amendment No. 1 to the contract	\$ 100,000
New Contract Not to Exceed Amount	\$ 179,626

The remaining services originally contemplated are detailed below, along with some items identified more recently.

- Maintenance Room Camera: An additional camera is being installed in the maintenance room. This work has been completed.

- Unit Electrical Upgrades: Each unit is furnished with a flow stop that turns off water to a faucet if moisture is detected in cabinets underneath the sink and was installed to assist with preventing flood damage to the unit. The installation of outlets under kitchen and bathroom sinks allows flow stops to run via AC adapters with battery back up instead of battery-operated only.

- Additional Services: Additional Services will be used for additional work that the owner requests in writing. A proposal of cost and scope of work must be submitted by the Consultant to the owner, approved and signed by ownership, and counter-signed by the Consultant prior to any initiation of work or accrued costs.

### **FISCAL IMPACT**

The contract between Mabuhay and Lakehurst LP and J.H. Fitzmaurice for building upgrades will total \$179,626. These funds are being paid by the development

### **CEQA**

n/a

### **RECOMMENDATION**

Authorize the President to Negotiate and Execute a First Amendment to the Consultant Services Agreement between Mabuhay and Lakehurst LP (Linnet Corner) and J.H. Fitzmaurice Increasing the Contract Amount by \$100,000 for a New Maximum Contract Amount Not to Exceed \$179,626, with an Existing Term of September 19, 2026, and Approved Option to Extend the Contract for One Six-Month Term to March 31, 2027.

### **ATTACHMENTS**

1. LC\_JHF\_Consultant\_Services\_Agreement\_Amendment\_No.1\_JHF\_Signature
2. May 20 2026 ICD BOD - Item 5.A Presentation

Respectfully submitted,



Jocelyn Layte, Associate Project Manager



## **FIRST AMENDMENT TO AGREEMENT**

This Amendment of the Agreement, entered into this 20 day of May 2026, by and between MABUHAY AND LAKEHURST LP, a California Limited Partnership (hereinafter referred to as "MLLP") and J.H. Fitzmaurice, Inc, a licensed general contractor whose address is 1466 66<sup>th</sup> street, Emeryville, CA 94608 (hereinafter referred to as "CONSULTANT") is made with reference to the following:

### **RECITALS:**

- A. On March 19<sup>th</sup>, 2026, an agreement was entered into by and between MLLP and Consultant (hereinafter "Agreement") for a not to exceed amount of \$79,626.90 with a contract term date of September 19, 2026, unless extended by mutual agreement an additional six months to March 19, 2027.

MLLP and Consultant desire to modify the Agreement on the terms and conditions set forth herein.

NOW, THEREFORE, it is mutually agreed by and between and undersigned parties as follows:

1. The not to exceed amount for the entire Agreement shall be increased by ONE HUNDRED THOUSAND DOLLARS AND ZERO CENTS (\$100,000.00) to be amended to ONE HUNDRED SEVENTY-NINE THOUSAND SIX HUNDRED AND TWENTY-SIX DOLLARS AND NINETY CENTS (\$179,626.90) for services.
2. The Scope of Services included as Exhibit A-1 to the original agreement is hereby replaced in its entirety with the amended Scope of Services attached to this amendment as Exhibit A-2.
3. The Fee Schedule included as Exhibit B-1 to the original agreement is hereby replaced in its entirety with the amended Fee Schedule attached to this amendment as Exhibit B-2.
4. Consultant confirms that all work completed to April 30<sup>th</sup>, 2026, has been invoiced and the invoices have been received by the MLLP. No late invoices that are received after the execution of this first amendment will be honored for payment for the period prior to March 31<sup>st</sup>, 2026.

Except as expressly modified herein, all other terms and covenants set forth in the Agreement shall remain the same and shall be in full force and effect.

[SIGNATURES ON FOLLOWING PAGE]

IN WITNESS WHEREOF, the parties hereto have caused this modification of the Agreement to be executed on the day and year first above written.

J.H. Fitzmaurice, Inc., a California Corporation

MABUHAY AND LAKEHURST LP, a California Limited Partnership

BY: ICD MABUHAY LLC, a California Limited Liability Company, Its managing general partner

By: ISLAND CITY DEVELOPMENT, a California Non-profit Public Benefit Corporation, Its sole manager

Signed by:

*Kyan Hakimi*

39E625F08CC14FA

Kyan Hakimi

Vice President/ PM

5/6/2026

Initial

*BV*

Vanessa Cooper  
President of Island City Development

Sylvia Martinez  
Director of Housing Development

**EXHIBIT A-1**  
**SCOPE OF SERVICES**

North Housing Block A, Linnet Corner  
2000 Lakehurst Circle, Alameda CA

Scope of services is as follows:

- **Atlantis Interiors Inc** to provide all labor, material, and equipment to replace old acoustic ceiling tiles with Armstrong Ultima 2x2 at offices 1125, 1130, 1130A, and 1130B only and upgrade the originally specified Armstrong Ultima #2082 Ceiling Panels to Armstrong Ultima Health Zone #1351.
- **Crockett Electric** to provide all labor, material, equipment to install a new dome camera in the Maintenance Office, remove all electrical devices, fixtures, smoke detectors and replace once new tile is replaced at rooms 1130, 1130B, and Per RFI response 308, add 1 outlet at kitchen sink and bathroom sink for flow stops.

\*\*\*Additional services as requested in writing by the owner to consultant. This will be work the owner requests in writing only to the Consultant. A proposal of cost and scope of work must be submitted by the Consultant to the owner, approved and signed by ownership, and counter signed by Consultant prior to any initiation of work or accrued costs.

- \* All work to be executed during regular working hours.
- \* An accessible indoor storage shall be provided by the owner.
- \* Scope of work excludes all costs associated with permits and inspection
- \* Removal and replacement of furniture in the rooms are excluded.

**EXHIBIT B-1**  
**FEE SCHEDULE**

<b>Description</b>	<b>Amount</b>	<b>Status</b>
C-1 Acoustic Ceiling Tiles	\$ 29,806.73	Completed
C-5 - Acoustic Ceiling Tile Upgrade to Health Zone	\$ 2,091.97	Completed
C-6 Maintenance Room Camera Wiring	\$ 4,062.17	Completed
C-8 Add Outlets at Unit Sinks	\$ 38,355.87	
<i>Contingency</i>	<i>\$ 105,310.16</i>	
<b>Total Contract</b>	<b>\$ 179,626.90</b>	

\*Completed status items have been paid at the time of this amendment.









# CHANGE ORDER REQUEST

**CROCKETT ELECTRIC CO**

3440 Pacheco Blvd  
Martinez, CA 94553

**CCN #** 31  
**Date:** 4/17/2026  
**Project Name:** North Housing Senior Phase  
**Project Number:** North Housing Senior Phase  
**Page Number:** 1

**JH Fitzmaurice**

Contact: Bashir Valizade  
2857 Hannah Street  
Oakland, CA 94608

---

**Work Description**

---

Per email from Bashir,  
Add 1 outlet at kitchen sink and bathroom sink for flow stops.

Wires to be concealed in wall from outlet above sink, to inside of base cabinet. Once inside base cabinet, surface flex to run to surface 1g box for single receptacle.

**Qualifications:**

- 1 - Entry to units to be scheduled so we can move fluently from one unit to the next.
  - 2 - Stand by time for not being able to gain entry into units, and waiting for cabinets to be cleared if not done prior to our arrival will be charged on a T&M basis
  - 3 - Cabinets need to be cleared of all belongings under the bathroom sink, kitchen sink, and the cabinets to the left and right of the sink
  - 4 - Countertop needs to be cleared on the left and right hand side of the sink.
  - 5 - We will not be responsible for clearing out cabinets or putting stuff back into cabinets.
  - 6 - All sheetrock patching and painting by others
- We reserve the right to correct this quote for errors and omissions.

We reserve the right to correct this quote for errors and omissions.

---

**Itemized Breakdown**

---

Description	Qty	Net Price U	Total Mat.	Labor U	Total Hrs.
Studio	40	26.30 E	1,052.00	2.25 E	90.00
1 Bed	24	20.05 E	481.20	2.00 E	48.00
<b>Totals</b>	<b>64</b>		<b>1,533.20</b>		<b>138.00</b>

---

**Summary**

---

**ORIGINAL**

**CHANGE ORDER REQUEST**

**JH Fitzmaurice**  
2857 Hannah Street  
Oakland, CA 94608

**CCN #** 31  
**Date:** 4/17/2026  
**Project Name:** North Housing Senior Phase  
**Project Number:** North Housing Senior Phase  
**Page Number:** 2

---

**Summary (Cont'd)**

General Materials		1,533.20
Material Tax	(@ 10.750 %)	164.82
<b>Total Material</b>		<b>1,698.02</b>
JOURNEYMAN	(138.00 Hrs @ \$151.00)	20,838.00
Markup	(@ 15.000 %)	3,380.40
<b>Subtotal</b>		<b>25,916.42</b>
<b>Final Amount</b>		<b>\$25,916.42</b>

**ORIGINAL**

**From:** [Bashir Valizade](#)  
**To:** [Jeremy Mears](#)  
**Cc:** [Adel Moghaddas](#); [Kyan Hakimi](#); [Ali Masoumi](#)  
**Subject:** Flow stops at Linnet and Estuary I  
**Date:** Thursday, April 16, 2026 9:39:45 AM  
**Attachments:** [Flow stop Submittal 018 R1.4.pdf](#)

---

Hi Jeremy,

Please see attached flow stop submittal and advise for below items. We do have these in 2 locations, kitchen sink faucets, and bathroom faucets under cabinets.

1. Kitchen – can we use the outlet under cabinets which is for waste disposal and dishwasher as source of power for the flow stop AC adaptors too. If need be, we can use a power splitter. Please confirm if this is acceptable the outlet is capable of these 3.
2. Bathroom – since we don't have any kind of source of power under bathroom cabinets, could you please provide me with a change order to be the easiest and cheapest power supply under cabinets for the flow stop AC adaptors.

Thanks,

Bashir A Valizade  
Assistant Project Manager  
J.H. Fitzmaurice, Inc.  
1466 66<sup>th</sup> St, Emeryville CA. 94608  
cell – 510-650-6855 [bashir@jhfoak.com](mailto:bashir@jhfoak.com)



**J.H. Fitzmaurice, Inc.**  
 2857 Hannah Street  
 Oakland, California 94608  
 P: 5104447561

**Project: 23846 North Housing PSH-I**  
 500 Mosley Avenue  
 Alameda, California 94501

## RFI #308: Add Outlets under Kitchen & Bathroom Cabinets

<b>Revision</b>	0	<b>Status</b>	Closed on 04/20/26
<b>To</b>	Jocelyn Layte (Housing Authority of the City of Alameda) Sam McGeehan (HKIT Architects)	<b>From</b>	Bashir Valizade (J.H. Fitzmaurice, Inc.)
<b>Date Initiated</b>	Apr 16, 2026	<b>Due Date</b>	Apr 23, 2026
<b>Location</b>		<b>Project Stage</b>	Post-Construction
<b>Cost Impact</b>	Yes (Unknown)	<b>Schedule Impact</b>	
<b>Spec Section</b>		<b>Cost Code</b>	
<b>Drawing Number</b>		<b>Reference</b>	
<b>Linked Drawings</b>			
<b>Received From</b>	Jeremy Mears (Crockett Electric Co.)		
<b>Copies To</b>	Kyan Hakimi (J.H. Fitzmaurice, Inc.), Jocelyn Layte (Housing Authority of the City of Alameda), Sylvia Martinez (Housing Authority of the City of Alameda), Ali Masoumi (J.H. Fitzmaurice, Inc.), Paul McElwee (HKIT Architects), Sam McGeehan (HKIT Architects), Jeremy Mears (Crockett Electric Co.), Adel Moghaddas (J.H. Fitzmaurice, Inc.), Joseph Nagel (Housing Authority of the City of Alameda), Bashir Valizade (J.H. Fitzmaurice, Inc.)		
<b>Priority Level</b>		<b>Identical to Senior</b>	No

### Activity

#### Question

**Question from Bashir Valizade J.H. Fitzmaurice, Inc. on Thursday, Apr 16, 2026 at 02:09 PM PDT**

1- To add outlets at all bathroom sinks, we propose fishing a wire from the outlet box above sink, down into the base cabinet. We will have to drill a hole in the side of the cabinet, and run surface flex inside the cabinet to a surface 1 gang box with a single outlet. Wiring will be concealed in wall from outlet to inside the cabinet.  
 2- To add the outlets at the kitchen sinks,  
 In the studio apartments we will fish a wire from the countertop outlets into the back side of the base cabinets, and run flex in the back of the cabinet to under the sink, to a surface mount 1 gang box with a single receptacle.  
 In the 1 bed and manager units there is already a single receptacle for the dishwasher. We will change the single receptacle to a duplex receptacle.

Please confirm if this is acceptable

**Attachments**

[NHPH1 RFI # 35 - add outlets at sinks in units.pdf](#)

**Official Response**

**Response from Bashir Valizade J.H. Fitzmaurice, Inc. on Monday, Apr 20, 2026 at 03:07 PM PDT**

Official response received via email, dt. 4/20/2026, see below.

Hi Bashir,

I just got a review and okay from HKIT. Please approve and move forward.

Thank you,

Jocelyn Layte (she/ her/ hers)

Associate Project Manager

**All Replies**

**Response from Bashir Valizade J.H. Fitzmaurice, Inc. on Monday, Apr 20, 2026 at 03:07 PM PDT**

Official response received via email, dt. 4/20/2026, see below.

Hi Bashir,

I just got a review and okay from HKIT. Please approve and move forward.

Thank you,

Jocelyn Layte (she/ her/ hers)

Associate Project Manager

# Agenda Item 5.A

## May 20, 2026 ICD Board of Directors Meeting

Presented by Jocelyn Layte  
Associate Project Manager



**5.A** Authorize the President to Negotiate and Execute a First Amendment to the Consultant Services Agreement between Mabuhay and Lakehurst LP (Linnet Corner) and J.H. Fitzmaurice Increasing the Contract Amount by \$100,000 for a New Maximum Contract Amount Not to Exceed \$179,626, with an Existing Term of September 19, 2026, and Approved Option to Extend the Contract for One Six-Month Term to March 31, 2027.



# Contract Work

- Acoustic upgrades
- Maintenance Room Camera
- Electrical upgrades





ISLAND CITY DEVELOPMENT

Fax (510) 522-7848 | TTY/TRS 711

To: Board of Directors  
Island City Development

From: Jocelyn Layte, Associate Project Manager

Date: May 20, 2026

Re: Authorize the President to Negotiate and Execute a First Amendment to the Consultant Services Agreement between Lakehurst and Mosley LP (The Estuary I) and J.H. Fitzmaurice Increasing the Contract Amount by \$100,000 for a New Maximum Contract Amount Not to Exceed \$307,772, with an existing term of September 19, 2026, and approved option to extend the contract for one six-month term to March 31, 2027.

**BACKGROUND**

The Estuary I project, located at 500 Mosley Avenue, includes 45 new construction permanent supportive housing units for unhoused or formerly unhoused individuals or households, including one manager’s unit. J.H. Fitzmaurice, Inc. (JHF) initiated construction on January 30, 2024, and received Certificate of Occupancy (COO) on August 21, 2025. The project has been fully leased as of August 31, 2025. JHF has continued to respond to warranty items and also to implement small additional changes requested by ICD to assist in smoother operations.

**DISCUSSION**

In October, upgrades were identified for the building which require a contractor to complete the work. Lakehurst and Mosley LP requested the work be done under the general contractor and subcontractors who originally worked on the project during construction, to preserve warranty rights.

In December 2025, the Board of Directors approved the contract for work between Mabuhay and Lakehurst LP and J.H. Fitzmaurice, which terminated as of February 28, 2026. A new contract with a term date of September 19, 2026, and an option to extend six months to March 31, 2027 was approved in March 2026. The proposed contract amendment will cover the costs of the remaining services needed for the property to receive the upgrades identified in the original contract and provide contingency for any final upgrades that may be identified before contract close out. Prior to contract amendment No.1, work for the water down spout reroutes, noise attenuation upgrades, ADO bathroom door upgrades and tile was completed.

Original contract amount	\$ 207,772
Work completed prior to May 1, 2026	\$ 73,410
Amendment No.1	\$ 100,000
New Contract Not to Exceed Amount	\$ 307,772

The remaining services which had been originally contemplated are detailed below, along



with some items that were identified more recently.

- Acoustic Panels: Acoustic panels are to be installed in all common nook areas at the end of the hallways, in the western corridor of the first floor, service offices, health room, and breakout room. This work was partially completed during the first contract.

- First Floor Bike Room Upgrades: The bicycle parking rooms are heavily utilized by the residents. To improve access, the bike rooms on all floors will have fob panels installed, including an Automatic Door Opener on the first floor. Staff had planned for this upgrade with all pre-wired locations, and the upgrade is being provided now to improve bike storage for tenants.

- Unit Electrical Upgrades: Each unit is furnished with a flow stop that turns off water to a faucet if moisture is detected in cabinets underneath the sink and was installed to assist with preventing flood damage to the unit. The installation of outlets under kitchen and bathroom sinks allows flow stops to run via AC adapters with battery backup instead of battery-operated only.

-Additional Services: Additional services will be work that the owner requests in writing over the next year. A proposal of cost and scope of work must be submitted by the Consultant to the owner, approved and signed by ownership, and countersigned by the Consultant prior to any initiation of work or accrued costs.

### **FISCAL IMPACT**

The contract between Lakehurst and Mosley LP and J.H. Fitzmaurice for building upgrades will total \$307,772. These funds are being paid by the development.

### **CEQA**

n/a

### **RECOMMENDATION**

Authorize the President to Negotiate and Execute a First Amendment to the Consultant Services Agreement between Lakehurst and Mosley LP (The Estuary I) and J.H. Fitzmaurice Increasing the Contract Amount by \$100,000 for a New Maximum Contract Amount Not to Exceed \$307,772, with an existing term of September 19, 2026, and approved option to extend the contract for one six-month term to March 31, 2027.

### **ATTACHMENTS**

1. Est\_I\_JHF\_Consultant\_Services\_Agreement\_Amendment\_No.1\_JHF\_Signature
2. May 20 2026 ICD BOD - Item 5.B Presentation

Respectfully submitted,



Jocelyn Layte, Associate Project Manager



## **FIRST AMENDMENT TO AGREEMENT**

This Amendment of the Agreement, entered into this 20 day of May 2026, by and between LAKEHURST AND MOSLEY LP, a California Limited Partnership (hereinafter referred to as "LMLP") and J.H. Fitzmaurice, Inc, a licensed general contractor whose address is 1466 66<sup>th</sup> street, Emeryville, CA 94608 (hereinafter referred to as "CONSULTANT") is made with reference to the following:

### **RECITALS:**

- A. On March 19<sup>th</sup>, 2026, an agreement was entered into by and between LMLP and Consultant (hereinafter "Agreement") for a not to exceed amount of \$207,772.52 with a contract term date of September 19, 2026.

LMLP and Consultant desire to modify the Agreement on the terms and conditions set forth herein.

NOW, THEREFORE, it is mutually agreed by and between and undersigned parties as follows:

1. The not to exceed amount for the entire Agreement shall be increased by ONE HUNDRED THOUSAND DOLLARS AND ZERO CENTS (\$100,000.00) to be amended to THREE HUNDRED AND SEVEN THOUSAND SEVEN HUNDREDD AND SEVENTY-TWO DOLLARS AND FIFTY-TWO CENTS (\$307,772.52) for services.
2. The Scope of Services included as Exhibit A-1 to the original agreement is hereby replaced in its entirety with the amended Scope of Services attached to this amendment as Exhibit A-2.
3. The Fee Schedule included as Exhibit B-1 to the original agreement is hereby replaced in its entirety with the amended Fee Schedule attached to this amendment as Exhibit B-2.
4. Consultant confirms that all work completed to April 30<sup>th</sup>, 2026, has been invoiced and the invoices have been received by the LMLP. No late invoices that are received after the execution of this first amendment will be honored for payment for the period prior to March 31<sup>st</sup>, 2026.

Except as expressly modified herein, all other terms and covenants set forth in the Agreement shall remain the same and shall be in full force and effect.

[SIGNATURES ON FOLLOWING PAGE]

IN WITNESS WHEREOF, the parties hereto have caused this modification of the Agreement to be executed on the day and year first above written.

J.H. Fitzmaurice, Inc., a California Corporation

LAKEHURST AND MOSLEY LP, a California Limited Partnership

BY: ICD LAKEHURST LLC, a California Limited Liability Company, Its managing general partner

By: ISLAND CITY DEVELOPMENT, a California Non-profit Public Benefit Corporation, Its sole manager

Signed by:

*Kyan Hakimi*

39F625F98CC44FA

Kyan Hakimi  
Vice President/ PM

5/6/2026

Vanessa Cooper  
President of Island City Development

Initial

*BV*

Sylvia Martinez  
Director of Housing Development

**EXHIBIT A-1**  
**SCOPE OF SERVICES**

North Housing Block A, Estuary I  
500 Mosley Avenue, Alameda CA

Scope of services is as follows:

- Atlantis Interiors Inc. provides all labor, material, and equipment for furnishing and installation of piedmont plug, acoustic wall panels, acoustic ceiling tiles at North Housing Block A, Estuary I per layout and elevations provided by HKIT.
- Crockett Electric: provides all labor, material, and equipment for owner's request, to: Install FOB readers at the bike storage rooms on the 2nd, 3rd, and 4th floor and Install wiring and connection to 1 new ADO and 2 actuators at bike room 1st floor; Install a wireless actuator bar below the existing card reader, a wireless receiver inside the existing Automatic Door Operator (ADO) and wire the receiver at first floor corridor restroom; Add 1 outlet at kitchen sink and bathroom sink for flow stops in each unit. Wires to be concealed in wall from outlet above sink, to inside of base cabinet. Once inside base cabinet, surface flex to run to surface 1g box for single receptacle.
- Basco Drywall provides all labor, material, and equipment for owner's request to demo drywall as needed to run wiring from outlet to ADO. Patch back drywall, texture and paint to blend. Cover & protect finishes. Bike room on the 1st floor, and Per submittal 68.1r1, paint rerouted RWL.
- Jackson's Hardware provides all labor, material, and equipment for owner's request to: provide 1 ea. Automatic door operator; 2 ea. Actuators, and 1 electric strike for bike room at 1st floor; provide 1 ea. Auto operator standard arm; furnish 1 ea. Actuator, 36" and 1 ea. Receiver, 433Mhz.
- House Construction provides all labor, material, and equipment for owner's request to install 1 automatic door operator, 2 actuators at 2 openings and added electric strike at bike room on the 1st floor, and replace the bent auto operator standard arm,
- Eagle Sheet metal provides all labor, material and equipment for owners request to: provide caps with neoprene and self-adhesive flashing at awning and gutter waning framing joints; upsize the entrance canopy RWL from 2"x3" to 3"x4"; Per submittal 68.1r1, cut and cap existing canopy downspout and redirect roof DS all the way down and tie it into canopy DS; Cut existing 3"x4" DS and install black air gap.
- KZ tile: Per owner's request, provide labor, material, and equipment to demo & replace the broken floor tile, grout and clean up. Tile to be utilized from the attic stock.

\*\*\*Additional services as requested in writing by the owner to consultant. This will be work the owner requests in writing only to the Consultant. A proposal of cost and scope of work must be submitted by the Consultant to the owner, approved and signed by ownership, and counter signed by Consultant prior to any initiation of work or accrued costs.

\* All work to be executed during regular working hours.

- \* An accessible indoor storage shall be provided by the owner.
- \* Scope of work excludes all costs associated with permits and inspection

**EXHIBIT B-1**  
**FEE SCHEDULE**

<b>Description</b>	<b>Amount</b>	<b>Status</b>
C-1 Piedmont Plug & Acoustic Wall Panels	\$ 99,605.47	
C-2 - Acoustic Ceiling Tiles	\$ 48,167.05	Completed
C-4 - Cap and Flashing	\$ 7,941.17	Completed
C-5 - Acoustic Ceiling Tile Upgrade	\$ 4,344.51	Completed
C-6 - ADO and Actuators at Bike Rooms & Fob at L2 - L\$	\$ 37,423.41	
C-7 - Upsize RWL from 2x3 to 3x4	\$ 407.23	Completed
C-8 Replace Opener Arm at Restroom 1190	\$ 1,017.07	
C-9 - Ceramic Tile & Actuator at Restroom 1190	\$ 3,902.60	Completed
C-10 - Reroute Roof DS & Tie into Canopy DS with a Y	\$ 2,114.48	
C-11 Add Outlets at Unit Sinks - Flow Stops - Not approved	\$ 26,767.41	
<i>Contingency</i>	\$ 76,082.12	
<b>Total Contract Amount</b>	<b>\$ 307,772.52</b>	

\*Completed status items have been paid at the time of this amendment.

















# JACKSON'S

100% EMPLOYEE OWNED  
HARDWARE · TOOLS · DECORATIVE PLUMBING · RENTALS · PAINT  
435 DuBois Street PO Box 10247 San Rafael, CA 94912-0247  
(415) 454-3740 FAX (415) 257-2630

---

March 5, 2026

J.H. Fitzmaurice, Inc.  
1466 66<sup>th</sup> Street  
Emeryville, CA 94608  
Attn: Bashir Valizade

Job: North Housing Block A – PSH 1

Ref: Change Order Request for Automatic Door Operator Standard Arm and Actuator

**To add the following arm for the automatic door operator, please add: \$190.00.**

**GROUP NO. 48**

Door: 1190

**BATHROOM**

3/0 x 6/8 x 1-3/4"

HM x HM

20 minutes

Each door to add:

Qty

1

1 ea. Auto Operator Standard Arm

4630-3077T

689

LCN

Price includes sales tax, and freight. Please let me know if there are any questions.

Sincerely,

Jon Hansen  
Contract Sales Manager

Automatic Operators

# 4630 Series "Auto-Equalizer"

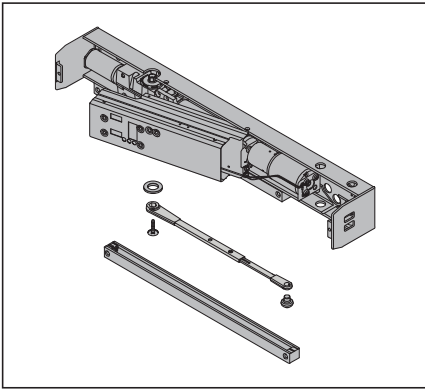

Cylinder & Cover Parts

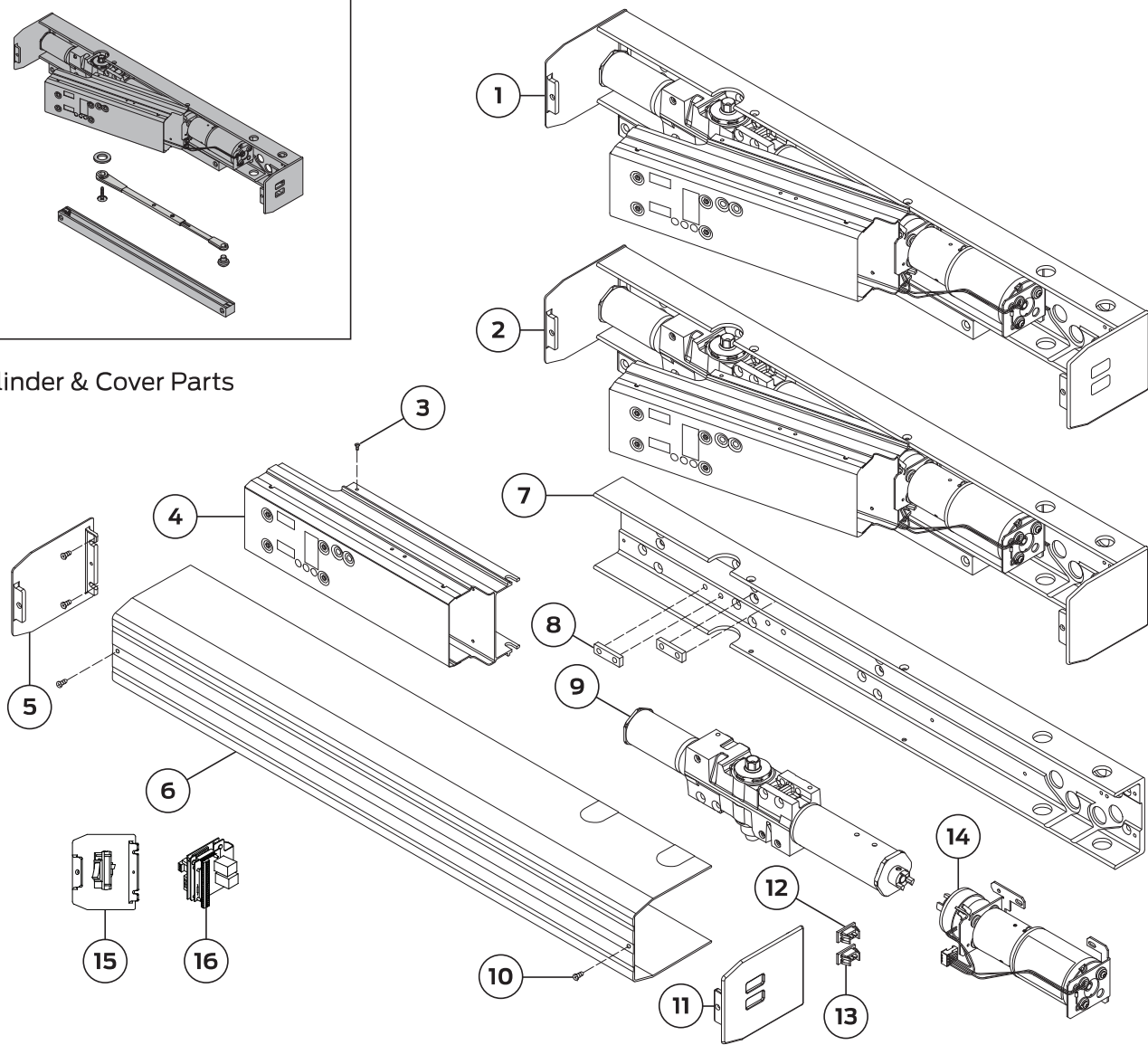

No.	Description	Part number
1	Cylinder Assembly (F)*	4632-3071
2	Cylinder Assy w/ Concealed I/O Switch (F)*	4632-3071CS
3	Controller Screw (F)	4630-31
4	Controller Assembly †	4630-3462
5	Blank Endcap ‡	4630-334-2
6	Metal Cover (F)§	4630-72MC
7	Mounting Plate Assembly	4630-3018
8	Stand-Off	4630-182

\* Includes Nos. 4, 7, 9. Cylinder is adjustable, size 1-4.

† Includes No. 3.

‡ Includes two Endcap Screws.

No.	Description	Part number
9	Cylinder Only (F)#	4632-3971
10	Cover Screw (F)	4631-31
11	Switch Endcap ‡	4630-334
12	On/Off Switch Assembly	4630-3179-1
13	Hold Open Switch Assembly	4630-3179-2
14	Motor/Clutch Assembly	4630-3454
15	Concealed Switch Endcap ‡	4630-334CS
16	I/O Board Assembly	4630-3180

§ Includes No. 10(2).

|| Includes Nos. 5, 8(2), 11, 12, 13, & 14 or Nos. 5, 8(2), 14, & 15.

# Cylinder is adjustable, size 1-4.

Please specify finish (F) where indicated. See the latest edition of the LCN catalog for part descriptions and specifications on many of the items shown above. List prices for items shown above can be located in the current LCN price book.

Automatic Operators

# 4630 Series "Auto-Equalizer"

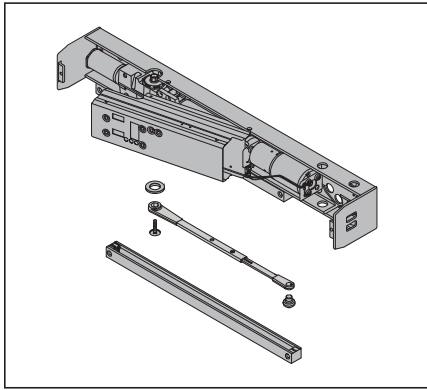

Arm & Additional Components

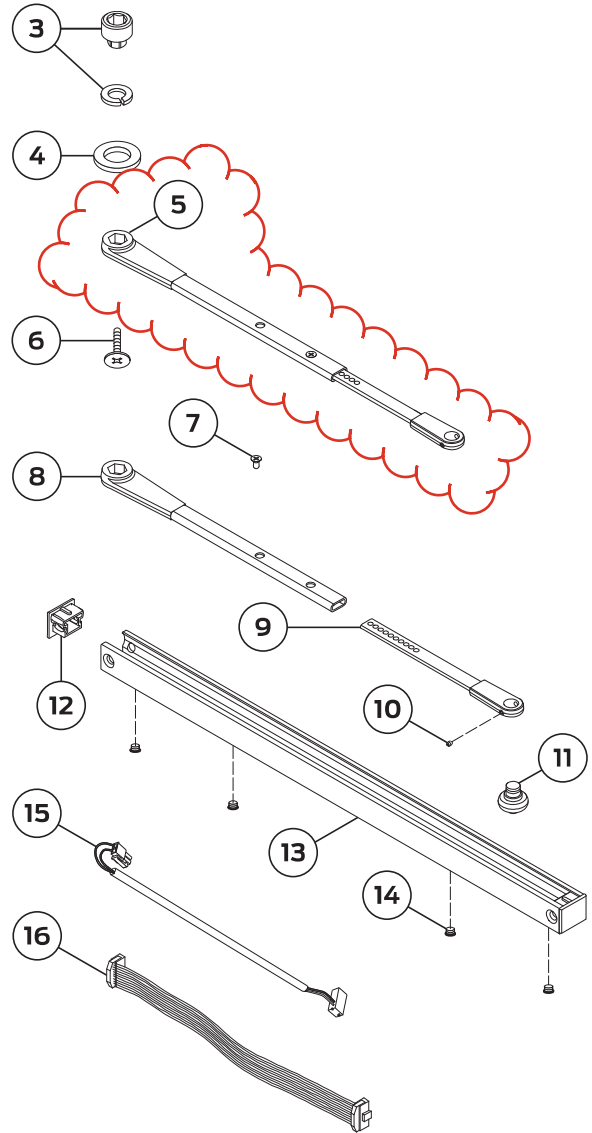
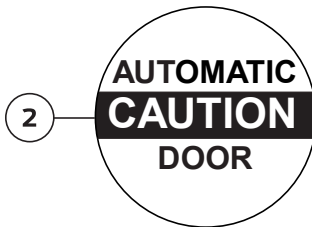
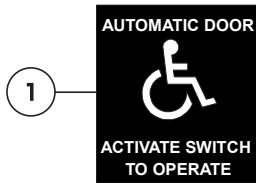

No.	Description	Part number
1	Activation Decal *	4630-155-2
2	Caution Decal †	4630-155-1
3	Shaft Extension Kit (F) ‡	4630-480
4	Shaft Spacer	4630-61
5	Standard Arm (F) §	4630-3077T
6	Arm Screw (F)	4630-159
7	H Arm Screw (F)	4630-83H
8	Arm & Tube (F)	4630-78
9	Rod (F) #	4630-82
10	Roller Lock Screw	4630-425

\* Blue/White Switch Decal.  
 † Black/Yellow Caution Decal.  
 ‡ Includes Extension, Lock Washer, & No. 6.  
 § Includes Nos. 4, 6, 7, 8, 9, & 10.

No.	Description	Part number
11	Track Roller	4630-3034
12	End Cap (F) (2 Required - Sold Individually)	4630-73
13	Standard Track (F) **	4630-3038
14	Plug (F) (4 Required - Sold Individually)	4630-141-2
15	A/C Power Cable	4630-3498-2
16	Ribbon Cable Connector	4630-3498-1
17	WMS Screw Pack (Not Shown)	4630-WMS
18	TBWMS Screw Pack (Not Shown)	4630-TBWMS
19	TORX Screw Pack (Not Shown)	4630-TORX
20	TBTRX Screw Pack (Not Shown)	4630-TBTRX

|| Includes No. 6.  
 # Includes Nos. 7 & 10.  
 \*\* Includes Nos. 12(2) & 14(4).

Please specify finish (F) where indicated. See the latest edition of the LCN catalog for part descriptions and specifications on many of the items shown above. List prices for items shown above can be located in the current LCN price book.



House Co. Construction  
1325 Howard Ave. #702  
Burlingame  
CA 94010  
(510)259-1144

10

**SUBCONTRACTOR CHANGE ORDER REQUEST**

Project: North Housing - PSH1

Date: 05-Mar-26

Address:

Attention:

Subcontractor: House Co (Labor)

**Description of Change:** Per GC Req - Install added operator and replace actuator arm

- Remove damaged arm from auto operator @ opening 1190

- Install Auto operator arm @ opening 1190

**Notes:**

- Labor only.

- Wiring by others and connection to electric systems by others

- Keyfobs readers by others.

- Door prep by others

**Additive Costs**

Labor

**Totals**

\$462.39

Material

Subtotal of Additive Cost

**\$462.39**

**Deductive Costs**

Hours

Rate

Labor

\$0.00

Subtotal of Deductive Cost

**\$0.00**

**Total Change Order Request**

**\$462.39**

Signed: \_\_\_\_\_

CC: \_\_\_\_\_

Date: \_\_\_\_\_



# JACKSON'S

100% EMPLOYEE OWNED  
HARDWARE · TOOLS · DECORATIVE PLUMBING · RENTALS · PAINT  
435 DuBois Street PO Box 10247 San Rafael, CA 94912-0247  
(415) 454-3740 FAX (415) 257-2630

---

March 17, 2026

J.H. Fitzmaurice, Inc.  
1466 66<sup>th</sup> Street  
Emeryville, CA 94608  
Attn: Bashir Valizade

Job: North Housing Block A – PSH 1

Ref: Change Order Request for Wireless Actuator at Bathroom Door 1190

**To add the following wireless actuator, please add: \$806.00.**

**GROUP NO. 48**

Door: 1190

**BATHROOM**

3/0 x 6/8 x 1-3/4"

HM x HM

20 minutes

Each door to add:

Qty

1 1 ea. Actuator, 36"  
1 1 ea. Receiver, 433Mhz

LPR36433 (wireless)  
10RD433

630 BEA  
---- BEA

Price includes sales tax, and freight to jobsite. Please let me know if there are any questions.

Sincerely,

Jon Hansen  
Contract Sales Manager



# LPR36

FULL-LENGTH, 36 INCH, HIGH-LOW ACTUATOR

**LEARN MORE**



click or scan

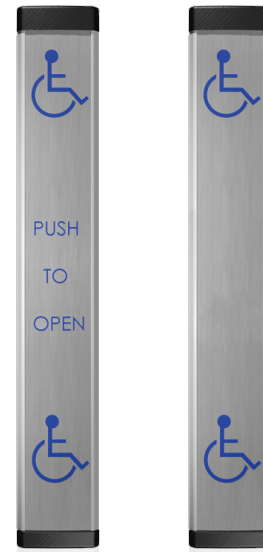

**DESCRIPTION**

BEA's **LPR36** is an actuator that exceeds ADA requirements, local and national building codes and standards. This 36-inch actuator provides a high/low actuator and eliminates the need to install two separate devices.

The stainless steel plate utilizes four highly sensitive membrane switches, ensuring actuation across the entire surface. This functionality enhances accessibility for those with limited mobility or disabilities.

Available in wireless and hardwire versions, the **LPR36** can be conveniently mounted in a variety of locations.



**Mobility-Assistance Device**

Offers a means of activation of automatic doors for those with limited mobility or disabilities

**Low Profile, Aesthetically Pleasing Design**

Low-profile (1 inch depth) design helps prevent accidental damage in high-traffic areas

**Standards Compliant**

Complies with requirements of a knowing-act device (per California Building Code 2022, 11B-404.2.9, Exception C), as well as ANSI 156.10, 156.19, 156.27, and 156.38

**Versatile Mounting**

Easily installs on walls or bollards for maximum mounting flexibility

**Easily Converts To Wireless**

Available with convenient, built-in wireless transmitter (300, 433, or 900 MHz frequencies) for wireless activation applications

**Full-Length Activation**

Activation area of 36 inches by 6 inches (216 square inches)

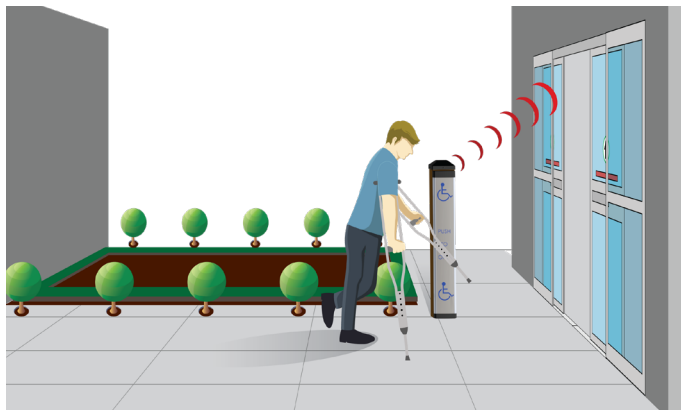

## APPLICATIONS



Sliding Doors

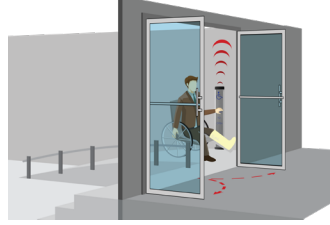

Swinging Doors



Revolving Doors

Not recommended for use in an environment where it will be directly exposed to water (e.g. outdoor, not protected from direct rain).

## PRODUCT SERIES



**10LPR36-300**  
300 MHz - text and logos



**10LPR36L-300**  
300 MHz - logos only



**10LPR36-433**  
433 MHz - text and logos



**10LPR36L-433**  
433 MHz - logos only



**10LPR36-900**  
900 MHz - text and logos



**10LPR36L-900**  
900 MHz - logos only



**10LPR36-HW**  
Hardwired - text and logos



**10LPR36L-HW**  
Hardwired - logos only

## TECHNICAL SPECIFICATIONS

### TECHNOLOGY / PERFORMANCE

**Contact Configurations** SPST N.O.

### ELECTRICAL

**Switching Voltage** < 50 VDC

**Switching Capacity** 1 Watt

**Switching Current** < 100 mA DC

### PHYSICAL

#### Material

Base 6063 aluminum

Face Plate 304 stainless steel

Switch Actuator nylon 66

End Cap UL94 ABS

Hardware stainless steel

**Operating temperature:** -32 – 212 °F (-35 – 100 °C)

### COMPLIANCE

#### Compliance

California Building Code 2022, 11B-404.2.9, Exception C  
ANSI 156.10, 156.19, 156.27, 156.38

## MOUNTING OPTIONS & ACCESSORIES



**10BOLLARDSLVWOH**  
Silver bollard without hole



**10BOLLARDBLKWOH**  
Black bollard without hole



**10BOLLARDBRZWOH**  
Bronze bollard without hole

**10LPRFACEPLATE-TL** Face plate replacement - text and logos

**10LPRFACEPLATE-LL** Face plate replacement - logos only

**10WCK433** Wireless conversion kit - (hardwired to wireless, 433 MHz)

**10WCK900** Wireless conversion kit - (hardwired to wireless, 900 MHz)

## RELATED PRODUCTS



**10R300**  
300 MHz analog receiver



**10RD433**  
433 MHz receiver



**10RD433EH**  
Extended hold time receiver



**10RD900**  
900 MHz receiver

LPR36 FULL-LENGTH, 36 INCH, HIGH-LOW ACTUATOR

**DISCLAIMER** Information is supplied upon the condition that the persons receiving it will make their own determination as to its suitability for their purposes prior to use. In no event will BEA be responsible for damages of any nature whatsoever resulting from the use of or reliance upon information from this document or the products to which the information refers. BEA has the right without liability to change descriptions and specifications at any time.

WWW.BEASENSORS.COM



BEA AMERICAS / RIDC Park West / 100 Enterprise Drive / Pittsburgh, PA  
T 1-800-523-2462 / F 1-888-523-2462 / E info-us@BEAsensors.com

A Halma company  
Page 117 of 136

# CHANGE ORDER REQUEST

## CROCKETT ELECTRIC CO

3440 Pacheco Blvd  
Martinez, CA 94553

**CCN #** 40  
**Date:** 3/12/2026  
**Project Name:** North Housing PSH 1  
**Project Number:** North Housing PSH 1  
**Page Number:** 1

Client Address:

### JH Fitzmaurice

Contact: Bashir Valizade  
2857 Hannah Street  
Oakland, CA 94608

---

### Work Description

---

We are pleased to present this proposal for access control modifications to add an actuator at Restroom 1190.

### Scope of Work

- Install a wireless actuator bar below the existing card reader.
- Install a wireless receiver inside the existing Automatic Door Operator (ADO)
- Wire the receiver to allow activation of the ADO only after a valid credential has been presented.
- The interior actuator will continue to activate the ADO whenever it is pushed.

### Clarifications

- The wireless actuator and associated receiver will be furnished by others.
- The actuator will be anchored to the wall using hollow wall anchors.
- The labor rates in this proposal expire December 31, 2026.

We reserve the right to correct this quote for errors and omissions.

---

### Itemized Breakdown

---

### Summary

---

AECO	(\$740.00 + 0.000 % + 0.000 % + 15.000 %)	851.00
<b>Subtotal</b>		<b>851.00</b>
<b>Final Amount</b>		<b>\$851.00</b>

ORIGINAL



415 Browning Way,  
 South San Francisco, CA 94080  
 Tel.: 650 875-9018  
 Fax: 650 875-5952  
 kztile@aol.com  
 License #767277

## Change Order Request

**1606 — North Housing Block A - PSH 1 COR Subject: Patch Restroom Floor Tile (Damaged by Others)**

<b>To</b>	Adel Moghaddas J.H. Fitzmaurice, Inc. 2857 Hannah Street Oakland, CA 94608	<b>1606-3(Patch Restroom Floor Tile)</b> <b>COR Number:</b> <b>COR Revision Number: 0</b> COR Date: 3/12/2026 Work Type: Field Work Order / T&M Days Valid: 5
<b>Return To</b>	Eunice Fang KZ Tile Company 415 Browning Way South San Francisco, CA 94080 (650)875-9018 (650)875-5952 (FAX) eunice@kztile.com	

### Details

Description	Cost / Rate	Qty / Hrs	Workers	Ext
Patch Restroom Floor Tile (Damaged by Others)	\$125.32	4.00 <i>Hrs</i>	1.00	\$501.28
Set Up, Demo Tile, Install Tile, Grout Tile and Clean Up				
CBP Prism SCG Single Component Grout # 643 Warm Gray, Thinset	\$95.07	1.00	-	\$95.07
Toll Fee	\$9.25	1.00	-	\$9.25

### Breakout

Labor :	\$501.28
Material :	\$95.07
Overhead Percent @ 15%:	\$14.26
Tax @ 9.875%:	\$9.39
Other :	\$9.25
<b>Total:</b>	<b>\$629.25</b>

## Reservation of Rights

This COR does not include any amount for impacts such as interference, disruptions, rescheduling, changes in the sequence of work, delays and/or associated acceleration. We expressly reserve the right to submit our request for any of these items.

---

**Signed By:** \_\_\_\_\_

**Dated:** 3/12/2026





**EAGLE SHEET METAL**

**4345 Sonoma Blvd. Unit A7.**  
**Vallejo, CA 94589**  
**Tel :510) 772-3613**  
**Email: eagle.sheetmetal@yahoo.com**

**EXTRA WORK AUTHORIZATION/CHANGE ORDER**

Date:4/03/2026

TO: JH.Fitzmaurice, Inc.  
 Project: North Housing Block A. PSH-1

NAME <u>Victor Garcia</u> HR _____ JOB PERFORMED <u>cut &amp; cap existing D/S coming from Canopy and re-direct to the wall next to the existing one. Cut existing one 3X4" to be able to connect The flex black vinyl filter and connect a Y to receive the 2x3" D/S coming from the roof thru the canopy</u>		
Material		\$ 250.00.
Fabrication	2 hrs. @.95	\$ 190.00
Installation	4 hrs @ 95	\$ 380.00
Labor Burden	35%	\$ 200
Profit	10%	\$ 82.00
		Total Price \$ 1,102.00

NOTE: This Change (s) becomes part of in conformance with the existing contract.  
 WE AGREE hereby to make the change(s) specified above at this Price:

BY:  
 Authorized Signature \_\_\_\_\_ Date \_\_\_\_\_ ACCEPTED

THE ABOVE PRICES AND SPECIFICATIONS OF THIS  
 CHANGES ARE SATISFACTORY AND ARE HEREBY ACCEPTED.  
 ALL WORK TO BE PERFORMED UNDER SAME TERMS AND  
 CONDITIONS AS SPECIFIED IN ORIGINAL CONTRACT UNLESS  
 OTHERWISE STIPULATED.



# Basco Drywall & Painting Co.

829 Estabrook Street • San Leandro, California 94577 • Phone (510) 357-3818 Fax (510) 483-6759

www.bascodrywallandpainting.com

## COST BREAKDOWN FORM FOR CONTRACT MODIFICATION

**Subcontractor:**

Company Name: Basco Drywall & Painting Co.  
 Contact: Chris Nelson  
 Address: 829 Estabrook Street  
 City, State Zip: San Leandro, CA 94577  
 Telephone: 510-357-3818  
 Fax: 510-483-6759

**Project:** JH Fitzmaurice, Inc.  
 North Housing Block A PSH 1 (Estuary)  
 500 Mosley Avenue  
 Alameda, CA 94501  
 Basco Job # 24-12  
 Date: April 3, 2026  
 Tag #  
 RFI #  
 COR# 16

**Description of work:** PSH1. - Painting of re routed RWL and vent to blend. As described in email 3-31-2026

LABOR				
NAME / CLASSIFICATION	HOURS	UOM	RATE	TOTAL
Carpenter Journeyman		hrs	\$ 115.00	\$ -
Taper Journeyman		hrs	\$ 110.00	\$ -
Painter Journeyman	4	hrs	\$ 107.30	\$ 429.20
Painter Journeyman (Premium Time)		hrs	\$ 61.93	\$ -
Painter Foreman		hrs	\$ 124.30	\$ -
Laborer		hrs	\$ 77.39	\$ -
Laborer (Premium Time)		hrs	\$ 57.24	\$ -
			<b>Labor Subtotal:</b>	<b>\$ 429.20</b>
Materials - itemized	Quan.	Unit	Unit Price	Extension
			<b>Materials Subtotal:</b>	<b>\$ -</b>

**Summary:**

	TOTAL COSTS
1. LABOR COSTS	\$ 429.20
2. 10.00% Overhead of Line 1	\$ 42.92
3. 5.00% Profit of Line 1	\$ 21.46
4. ADD Lines 1,2 & 3	\$ 493.58
5. TOTAL MATERIAL COSTS	\$ -
6. 10.75% tax of Line 5	\$ -
7. 10.00% Overhead of Line 5 & 6	\$ -
8. 5.00% Profit of Line 5 & 6	\$ -
9. ADD Lines 5, 6, 7 & 8	\$ -
<b>TOTAL COST OF REVISED SCOPE</b>	<b>\$ 493.58</b>



**J.H. Fitzmaurice, Inc.**  
 2857 Hannah Street  
 Oakland, California 94608  
 P: 5104447561

**Project: 23846 North Housing PSH-I**  
 500 Mosley Avenue  
 Alameda, California 94501

## Submittal #076200-4.1 - NHBA-23846-SUB-068.1R1 Reroute Roof DS & Tie it into the Canopy DS with a Y 076200 - Sheet Metal Flashing and Trim

<b>Revision</b>	1	<b>Submittal Manager</b>	Bashir Valizade (J.H. Fitzmaurice, Inc.)
<b>Status</b>	Open	<b>Date Created</b>	Mar 30, 2026
<b>Issue Date</b>	Mar 30, 2026	<b>Spec Section</b>	076200 - Sheet Metal Flashing and Trim
<b>Responsible Contractor</b>	Eagle Sheet Metal	<b>Received From</b>	
<b>Received Date</b>	Mar 17, 2026	<b>Submit By</b>	Mar 17, 2026
<b>Final Due Date</b>	Apr 13, 2026	<b>Lead Time</b>	
		<b>Cost Code</b>	
<b>Location</b>		<b>Type</b>	Shop Drawing

**Submittal Package**

**Approvers** Jocelyn Layte (Housing Authority of the City of Alameda)

**Ball in Court** Bashir Valizade (J.H. Fitzmaurice, Inc.)

**Distribution** Adel Moghaddas (J.H. Fitzmaurice, Inc.), Ali Masoumi (J.H. Fitzmaurice, Inc.), Bashir Valizade (J.H. Fitzmaurice, Inc.), Jocelyn Layte (Housing Authority of the City of Alameda), Joseph Nagel (Housing Authority of the City of Alameda), Kyan Hakimi (J.H. Fitzmaurice, Inc.), Mikail Shafique (J.H. Fitzmaurice, Inc.), Sylvia Martinez (Housing Authority of the City of Alameda), Victor Garcia (Eagle Sheet Metal)

**Description**

**Priority** Normal **Identical to Senior** No

**Reviewed By JHF** No

**Submittal Workflow**

Name	Sent Date	Due Date	Returned Date	Response	Attachments
General Information Attachments					<a href="#">Reroute Roof DS &amp; Tie it into the Canop DS with a Y.pdf</a>
Jocelyn Layte	Mar 30, 2026	Apr 13, 2026	Mar 31, 2026	Approved as Noted	
<b>Comment</b>	Please ensure where able that the air vent piece matches the DS color.				



Cut and cap here. Then reroute roof DS and tie it into the canopy DS with a Y.

Extend the 2"x3" roof DS and tie it to canopy DS with a "Y" as shown.  
Add below air gap at the awning DS above the Y-connection

East Spo... 10PM 99212 What can we help you find today?

**Flex Grate Black Vinyl Downspout Filter**  
by Amerimax Home Products >  
★★★★★ (657)  
• Filters debris from downspout before it can enter drainage system  
• Crush resistant, dent and rust proof vinyl design for durability  
• Fits both 2"x3" and 3"x4" downspouts to connect to 4 in drainage  
Color: **Black**

## Bashir Valizade

---

**From:** Paul Gorka <paul@vestismfg.com>  
**Sent:** Friday, March 27, 2026 11:23 AM  
**To:** Bashir Valizade  
**Cc:** James Vallance; Ricky Poon; Ali Masoumi; Adel Moghaddas; Mikail Shafique; KJ JHF; Kyan Hakimi  
**Subject:** Re: North Housing PSH-I: Submittal Distributed: (#19.0: NHBA-23846-SUB-148 Canopy Sample)

Point 2

Thanks!

Paul Gorka, Director of Engineering  
(509)714-1381

On Fri, Mar 27, 2026 at 9:25 AM Bashir Valizade <[bashir@jhfoak.com](mailto:bashir@jhfoak.com)> wrote:

Hi Paul,

Thanks for the response. Could you please let me know where this air gap needs to be installed, at awning DS or roof DS, 1 or 2 from below sketch.

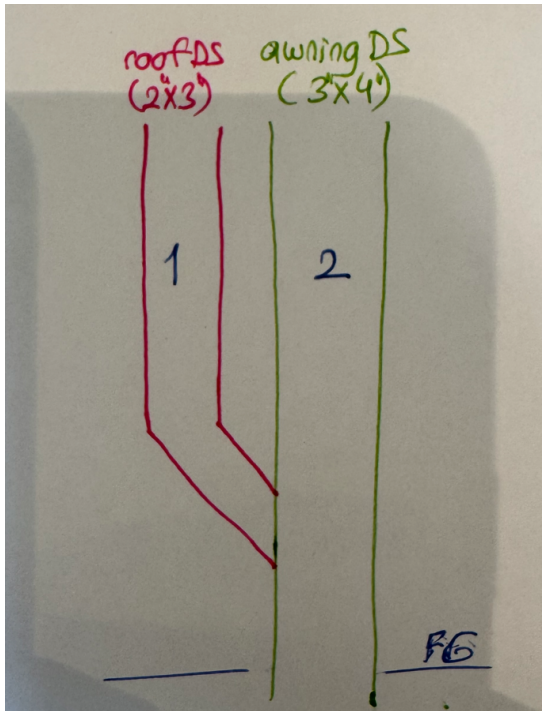

Thanks again,

Bashir

---

**From:** Paul Gorka <[paul@vestismfg.com](mailto:paul@vestismfg.com)>  
**Sent:** Thursday, March 26, 2026 5:22 PM  
**To:** Bashir Valizade <[bashir@jhfoak.com](mailto:bashir@jhfoak.com)>  
**Cc:** James Vallance <[james@vestismfg.com](mailto:james@vestismfg.com)>; Ricky Poon <[ricky@vestismfg.com](mailto:ricky@vestismfg.com)>; Ali Masoumi <[ali@jhfoak.com](mailto:ali@jhfoak.com)>; Adel Moghaddas <[adel@jhfoak.com](mailto:adel@jhfoak.com)>; Mikail Shafique <[mikail@jhfoak.com](mailto:mikail@jhfoak.com)>; KJ JHF <[kj@jhfoak.com](mailto:kj@jhfoak.com)>; Kyan Hakimi <[kyan@jhfoak.com](mailto:kyan@jhfoak.com)>  
**Subject:** Re: North Housing PSH-I: Submittal Distributed: (#19.0: NHBA-23846-SUB-148 Canopy Sample)

Bashir,

Thanks for the markup. We would still be concerned with a shared connection causing a back up and preventing the free-flow of water from the canopy. To prevent a vacuum, can you add an air gap above the Y-connection? Example picture is below, something with this effect would be terrific.

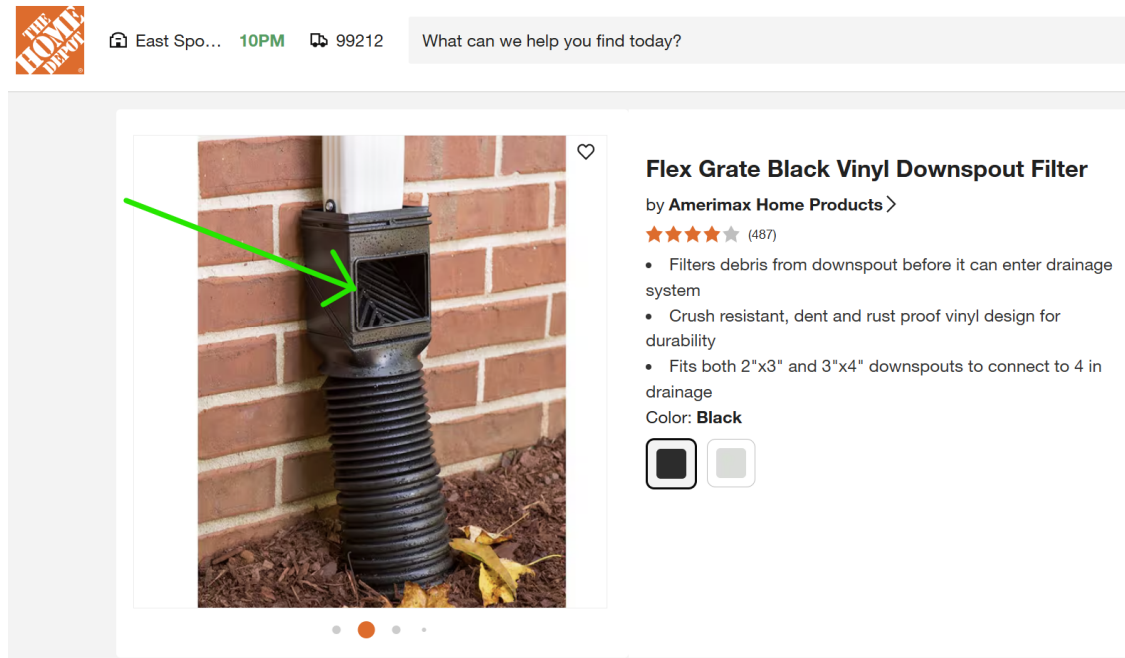

Thank you,



# CHANGE ORDER REQUEST

**CROCKETT ELECTRIC CO**

3440 Pacheco Blvd  
Martinez, CA 94553

**CCN #** 41  
**Date:** 4/17/2026  
**Project Name:** North Housing PSH 1  
**Project Number:** North Housing PSH 1  
**Page Number:** 1

Client Address:

**JH Fitzmaurice**

Contact: Bashir Valizade  
2857 Hannah Street  
Oakland, CA 94608

---

**Work Description**

---

Per email from Bashir,  
Add 1 outlet at kitchen sink and bathroom sink for flow stops.

Wires to be concealed in wall from outlet above sink, to inside of base cabinet. Once inside base cabinet, surface flex to run to surface 1g box for single receptacle.

**Qualifications:**

- 1 - Entry to units to be scheduled so we can move fluently from one unit to the next.
- 2 - Stand by time for not being able to gain entry into units, and waiting for cabinets to be cleared if not done prior to our arrival will be charged on a T&M basis
- 3 - Cabinets need to be cleared of all belongings under the bathroom sink, kitchen sink, and the cabinets to the left and right of the sink
- 4 - Countertop needs to be cleared on the left and right hand side of the sink.
- 5 - We will not be responsible for clearing out cabinets or putting stuff back into cabinets.
- 6 - All sheetrock patching and painting by others

We reserve the right to correct this quote for errors and omissions.

---

**Itemized Breakdown**

---

Description	Qty	Net Price U	Total Mat.	Labor U	Total Hrs.
Studio	24	26.30 E	631.20	2.25 E	54.00
1 Bed	21	20.05 E	421.05	2.00 E	42.00
<b>Totals</b>	<b>45</b>		<b>1,052.25</b>		<b>96.00</b>

---

**Summary**

---

General Materials		1,052.25
Material Tax (@ 10.750 %)		113.12

---

**ORIGINAL**

**CHANGE ORDER REQUEST**

**CROCKETT ELECTRIC CO**

3440 Pacheco Blvd  
Martinez, CA 94553

Client Address:

**JH Fitzmaurice**  
2857 Hannah Street  
Oakland, CA 94608

**CCN #**

**41**

**Date:**

4/17/2026

**Project Name:**

North Housing PSH 1

**Project Number:**

North Housing PSH 1

**Page Number:**

2

---

**Summary (Cont'd)**

<b>Total Material</b>		<b>1,165.37</b>
JOURNEYMAN	(96.00 Hrs @ \$151.00)	14,496.00
Markup	(@ 15.000 %)	2,349.21
<b>Subtotal</b>		<b>18,010.58</b>
<b>Final Amount</b>		<b>\$18,010.58</b>

**ORIGINAL**

**From:** [Bashir Valizade](#)  
**To:** [Jeremy Mears](#)  
**Cc:** [Adel Moghaddas](#); [Kyan Hakimi](#); [Ali Masoumi](#)  
**Subject:** Flow stops at Linnet and Estuary I  
**Date:** Thursday, April 16, 2026 9:39:45 AM  
**Attachments:** [Flow stop Submittal 018 R1.4.pdf](#)

---

Hi Jeremy,

Please see attached flow stop submittal and advise for below items. We do have these in 2 locations, kitchen sink faucets, and bathroom faucets under cabinets.

1. Kitchen – can we use the outlet under cabinets which is for waste disposal and dishwasher as source of power for the flow stop AC adaptors too. If need be, we can use a power splitter. Please confirm if this is acceptable the outlet is capable of these 3.
2. Bathroom – since we don't have any kind of source of power under bathroom cabinets, could you please provide me with a change order to be the easiest and cheapest power supply under cabinets for the flow stop AC adaptors.

Thanks,

Bashir A Valizade  
Assistant Project Manager  
J.H. Fitzmaurice, Inc.  
1466 66<sup>th</sup> St, Emeryville CA. 94608  
cell – 510-650-6855 [bashir@jhfoak.com](mailto:bashir@jhfoak.com)



**J.H. Fitzmaurice, Inc.**  
 2857 Hannah Street  
 Oakland, California 94608  
 P: 5104447561

**Project: 23846 North Housing PSH-I**  
 500 Mosley Avenue  
 Alameda, California 94501

## RFI #308: Add Outlets under Kitchen & Bathroom Cabinets

<b>Revision</b>	0	<b>Status</b>	Closed on 04/20/26
<b>To</b>	Jocelyn Layte (Housing Authority of the City of Alameda) Sam McGeehan (HKIT Architects)	<b>From</b>	Bashir Valizade (J.H. Fitzmaurice, Inc.)
<b>Date Initiated</b>	Apr 16, 2026	<b>Due Date</b>	Apr 23, 2026
<b>Location</b>		<b>Project Stage</b>	Post-Construction
<b>Cost Impact</b>	Yes (Unknown)	<b>Schedule Impact</b>	
<b>Spec Section</b>		<b>Cost Code</b>	
<b>Drawing Number</b>		<b>Reference</b>	
<b>Linked Drawings</b>			
<b>Received From</b>	Jeremy Mears (Crockett Electric Co.)		
<b>Copies To</b>	Kyan Hakimi (J.H. Fitzmaurice, Inc.), Jocelyn Layte (Housing Authority of the City of Alameda), Sylvia Martinez (Housing Authority of the City of Alameda), Ali Masoumi (J.H. Fitzmaurice, Inc.), Paul McElwee (HKIT Architects), Sam McGeehan (HKIT Architects), Jeremy Mears (Crockett Electric Co.), Adel Moghaddas (J.H. Fitzmaurice, Inc.), Joseph Nagel (Housing Authority of the City of Alameda), Bashir Valizade (J.H. Fitzmaurice, Inc.)		
<b>Priority Level</b>		<b>Identical to Senior</b>	No

### Activity

#### Question

**Question from Bashir Valizade J.H. Fitzmaurice, Inc. on Thursday, Apr 16, 2026 at 02:09 PM PDT**

1- To add outlets at all bathroom sinks, we propose fishing a wire from the outlet box above sink, down into the base cabinet. We will have to drill a hole in the side of the cabinet, and run surface flex inside the cabinet to a surface 1 gang box with a single outlet. Wiring will be concealed in wall from outlet to inside the cabinet.  
 2- To add the outlets at the kitchen sinks,  
 In the studio apartments we will fish a wire from the countertop outlets into the back side of the base cabinets, and run flex in the back of the cabinet to under the sink, to a surface mount 1 gang box with a single receptacle.  
 In the 1 bed and manager units there is already a single receptacle for the dishwasher. We will change the single receptacle to a duplex receptacle.

Please confirm if this is acceptable

**Attachments**

[NHPH1 RFI # 35 - add outlets at sinks in units.pdf](#)

**Official Response**

**Response from Bashir Valizade J.H. Fitzmaurice, Inc. on Monday, Apr 20, 2026 at 03:07 PM PDT**

Official response received via email, dt. 4/20/2026, see below.

Hi Bashir,

I just got a review and okay from HKIT. Please approve and move forward.

Thank you,

Jocelyn Layte (she/ her/ hers)

Associate Project Manager

**All Replies**

**Response from Bashir Valizade J.H. Fitzmaurice, Inc. on Monday, Apr 20, 2026 at 03:07 PM PDT**

Official response received via email, dt. 4/20/2026, see below.

Hi Bashir,

I just got a review and okay from HKIT. Please approve and move forward.

Thank you,

Jocelyn Layte (she/ her/ hers)

Associate Project Manager

# Agenda Item 5.B

## May 20, 2026 ICD Board of Directors Meeting

Presented by Jocelyn Layte  
Associate Project Manager



**Item 5.B.** Authorize the President to Negotiate and Execute a First Amendment to the Consultant Services Agreement between Lakehurst and Mosley LP (The Estuary I) and J.H. Fitzmaurice Increasing the Contract Amount by \$100,000 for a New Maximum Contract Amount Not to Exceed \$307,772, with an existing term of September 19, 2026, and approved option to extend the contract for one six-month term to March 31, 2027.



# Contract Work

- Acoustic Upgrades
- Bike room Upgrades
- Electrical upgrades

